

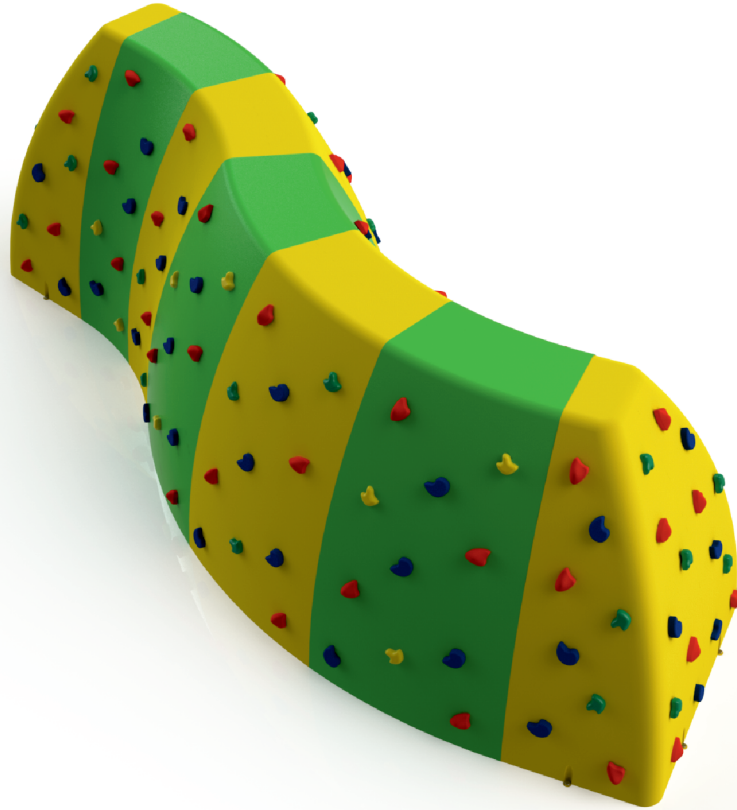

SANDVIK PLAY

KLATREMODUL 3

14-ELEM003



69,00m ²	1,80m	+3	1

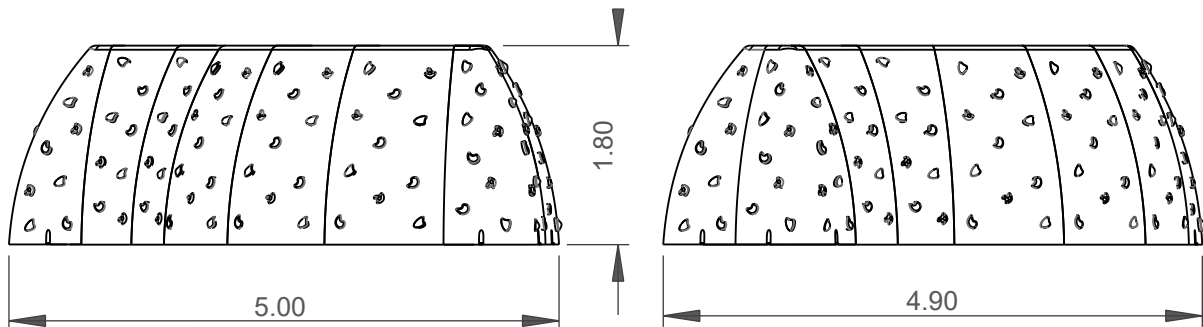



Utilização do equipamento sujeito a condições vigiadas; Zona de segurança: Área mínima requerida pela norma EN 1176-1,6
Utilización del equipo sujeto a condiciones vigiladas; Zona de seguridad: Área mínima requerida por la norma EN 1176-1,6
Use of equipment subject to supervised conditions; Safety zone: Minimum area required by EN 1176-1,6
Utilisation d'équipement soumis à des conditions supervisées; Zone de sécurité: Surface minimale requise par l'EN 1176-1,6





GB.047.01

— Zona de impacto
 - - Espaço livre

EN 1176-1 

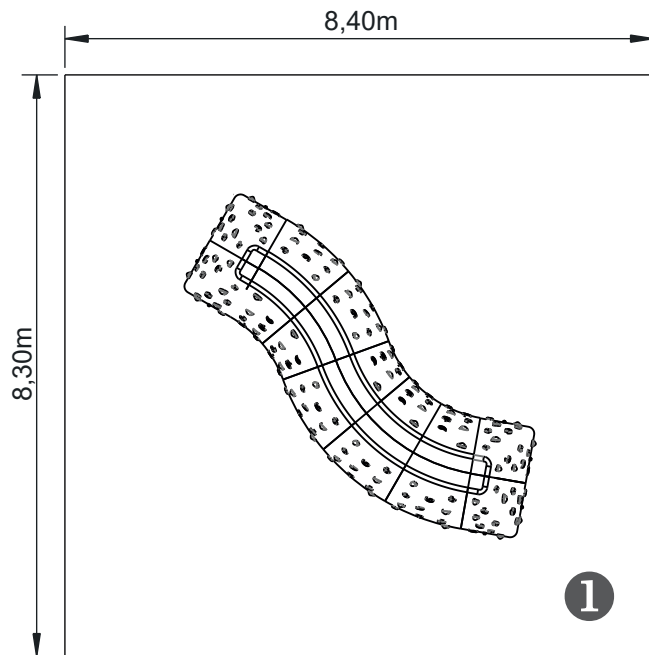
.....	①
	1.80
	69
	69



0,1 m³

3h

2x

KG

KG

1 - Escalada Modular  1.80m

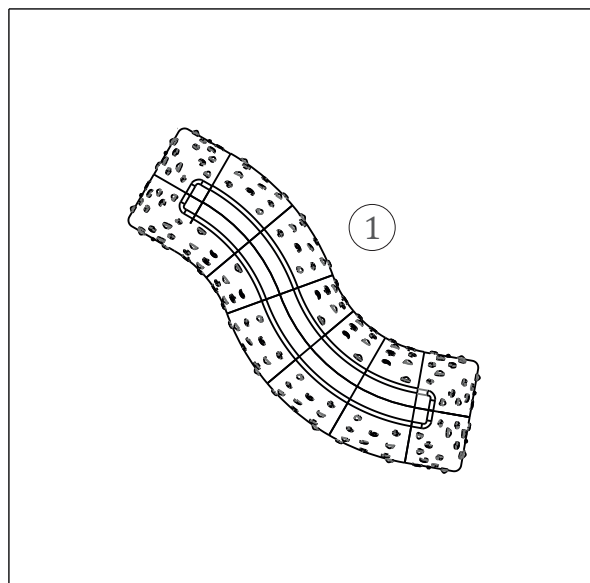



Climbing Panels

Fiberglass in layers. Single pieces of flat surface;

Climbing Stones

Polyester resin with mineral filler (silica) and dyes. Various sizes, colors and shapes;

Metal parts

Interior Structure: rectangular steel section tube;

Fixation System:

Type A – Standard fixing system composed of metal base embedded in the ground and cast with concrete;

Screws and accessories

Screws: Zinc-plated steel or optionally AISI 304 stainless steel;

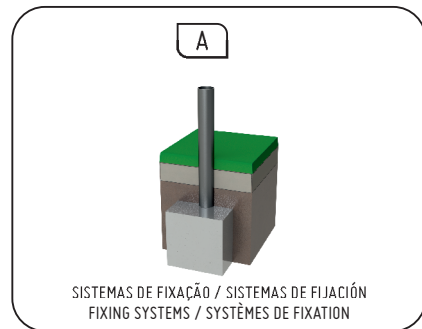

Fun

While having fun, children acquire immense abilities, from physical abilities to social interactions.



Socializing

Socialization and imagination are necessary throughout the game. All this creates a relationship between children and awakens the sense of coexistence and solidarity.



Play

Develops patience, sharing and sporting spirit.



Climb

It develops children's motor skills, body control, balance and coordination, stimulating motor ability and strength in movements.

