

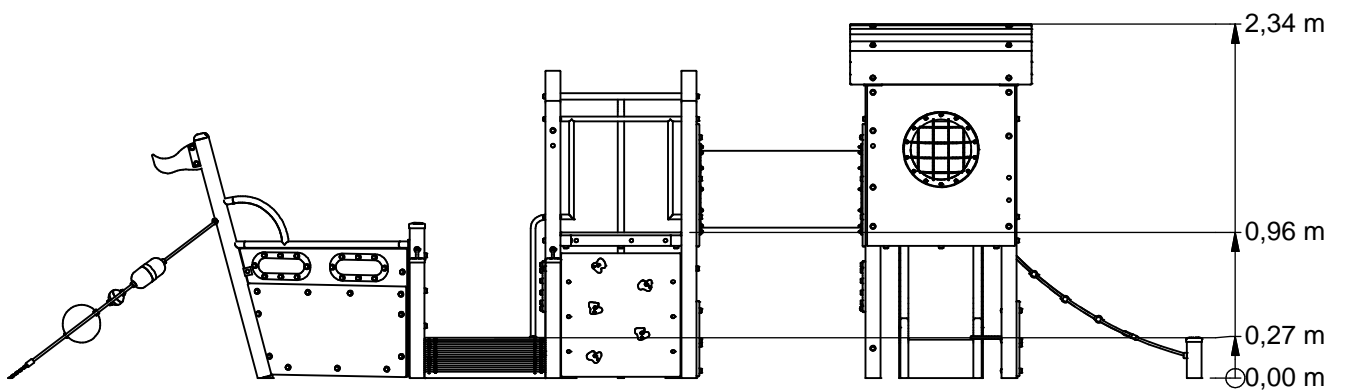

Ship

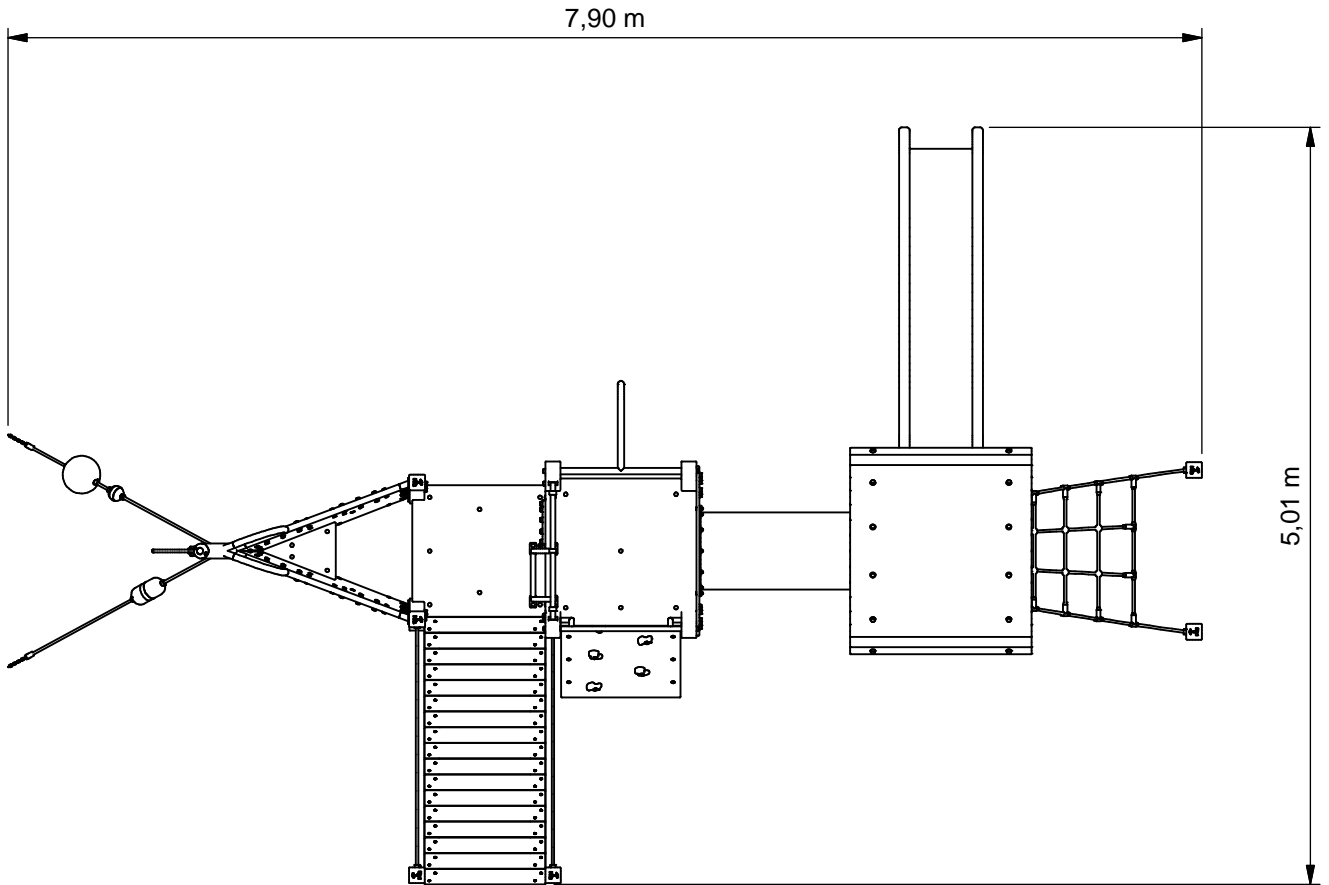

MNPE403.001



Benaming
Title Schip

Opmerking
Comment Groot

Datum
Date 28-8-2015

Tekening
Drawing

TOE MNP 403 001

Hoofdafmetingen *Main dimensions*

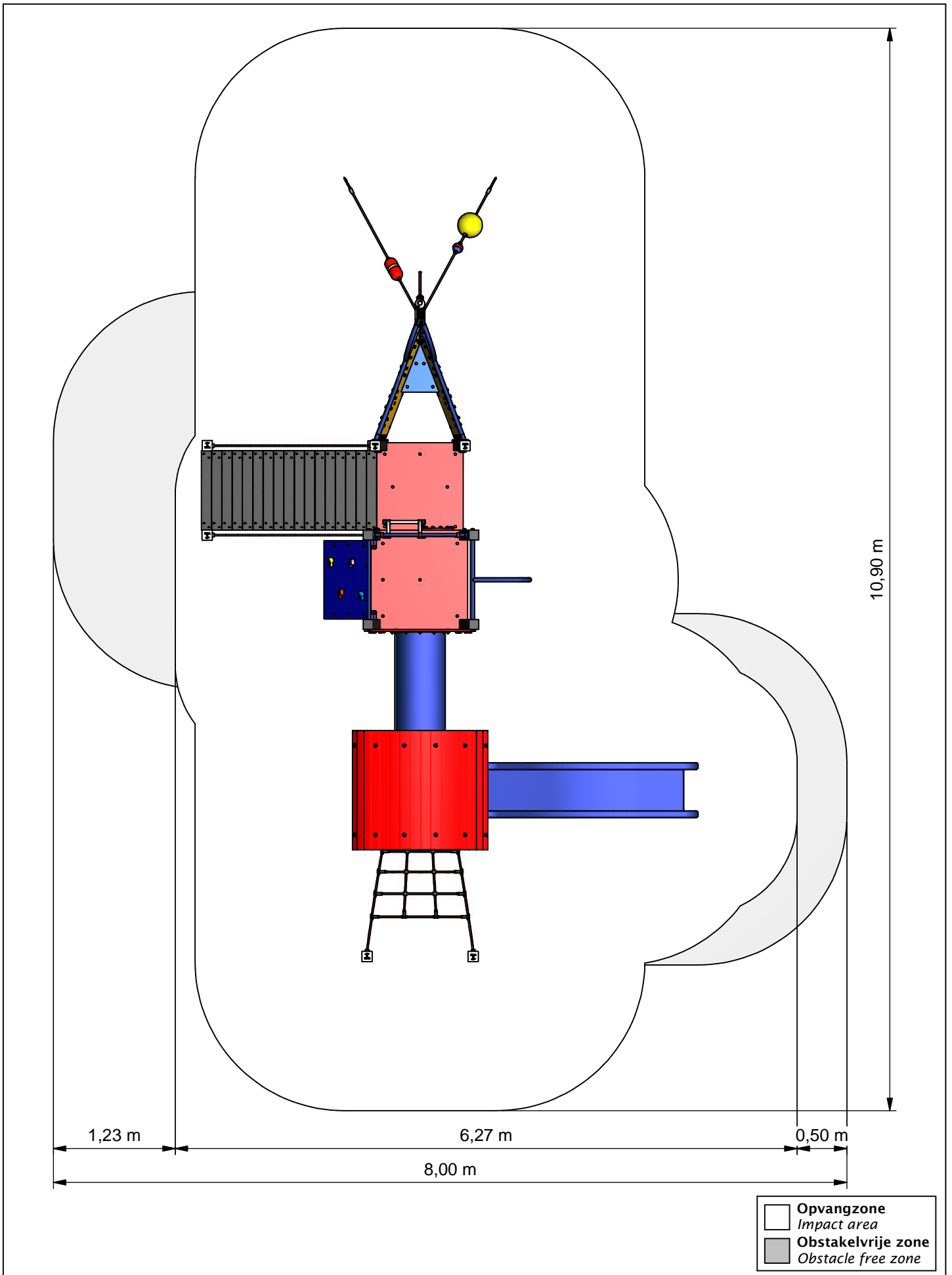

Benaming / Title: Schip
 Opmerking / Comment: Groot
 Datum / Date: 28-8-2015

Tekening / Drawing

TOE MNP 403 001

Obstakelvrije zone / Obstacle free zone

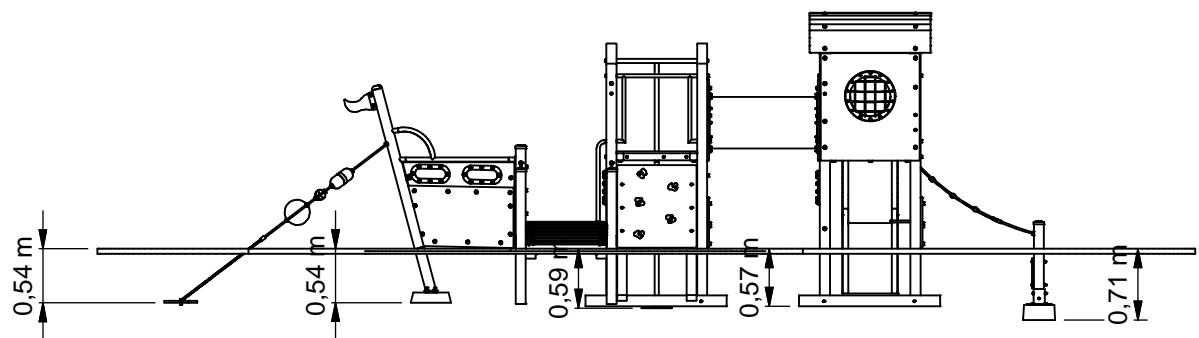
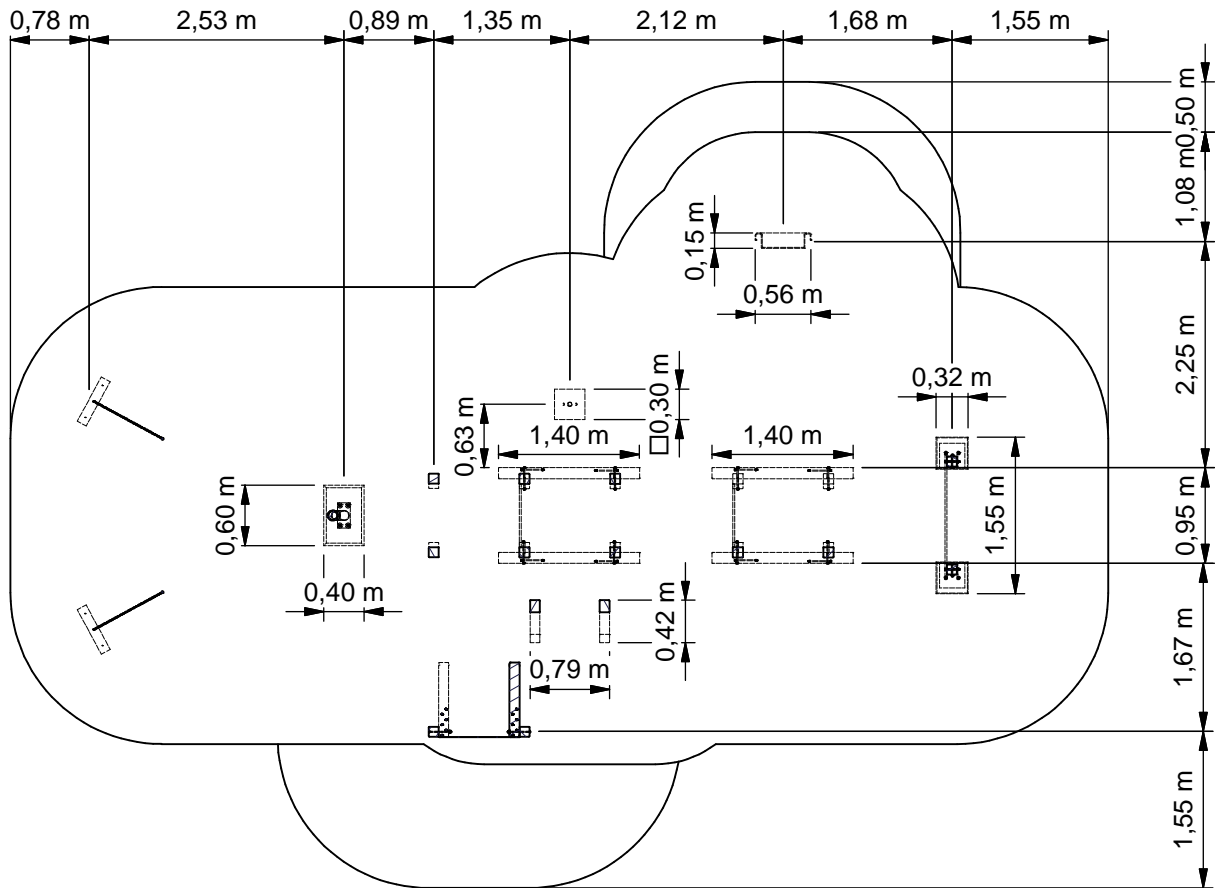

Benaming / Title: Schip
 Opmerking / Comment: Groot
 Datum / Date: 28-8-2015

Tekening / Drawing

TOE MNP 403 001

Bodemplan Groundplan

Geleverde modules:

Zie tabel

Supplied modules:

See table

Montageinstructie:

- De hoofdmaten geven de maten van de staanders en vloeren aan
- De detailtekeningen geven specifiek de maten van de verbindingen aan
- De modules met buizen zijn op de tekeningen bemaat op bovenkant kopplaat
- Overige modules zijn bemaat op de bovenkant (klimwanden, paalkappen, etc.)

Assembly instruction:

- The main dimensions indicate the dimensions of the posts and floors
- The detailed dimensions show the specific dimensions of the connections
- The modules which contain tubes are dimensioned at the top of the flanges
- Other modules are dimensioned at the top (climbing walls, caps for the posts, etc.)

Montagevolgorde:

- 1 - Graaf de gaten volgens het bodemplan
- 2 - Plaats Toren 1 (1,2,5,6,8,9(2x),12,14,16)
- 3 - Plaats Toren 2 (1,7,12,14,15,19,20)
- 4 - Verbind Toren 1 en Toren 2 met 17
- 5 - Plaats 3
- 6 - Verbind 3 en Toren 2 met 4
- 7 - Plaats 10,11,13,18,21,22,23
- 8 - Controleer of het toestel voldoet aan de afmetingen zoals op blad 'afmetingen'
- 9 - Dicht de gaten en verdicht het zand

Assembly sequence:

- 1 - Dig the holes according to the ground plan
- 2 - Place Tower 1 (1,2,5,6,8,9(2x),12,14,16)
- 3 - Place Tower 2 (1,7,12,14,15,19,20)
- 4 - Connect the two towers using 17
- 5 - Place 3
- 6 - Connect 3 and Tower 2 using 4
- 7 - Place 10,11,13,18,21,22,23
- 8 - Check that the equipment conforms to the dimensions shown on sheet 'dimensions'
- 9 - Close the holes and compact the sand

Controles:

- 1 - Correcte opbouw en alle bevestigingsmiddelen
- 2 - Controleer de afmetingen van de valbodem t.o.v. het toestel

Checks:

- 1 - Correct assembly and all the fasteners
- 2 - Check the dimensions of the safety area with regard to the play equipment

Nr	#	Type	Progr.	Volgnr	Bew.	Rev.	Benaming	Opmerking
1	2	MOD	FRP	KST	080		Schoren	incl. bevestiging
2	1	MOD	MNP	341	017		Dak	Tractor/Trein
3	1	MOD	MNP	401	002		Boeg	Schip
4	1	MOD	MNP	401	003		Vlonder	Schip
5	1	MOD	MNP	401	004		Bordes	Schip
6	1	MOD	MNP	401	005		Stuur	Schip
7	1	MOD	MNP	401	006		Wandje	Met raam
8	1	MOD	MNP	401	007		Wand	Tralievenster
9	2	MOD	MNP	401	008		Handgreep	Schip
10	1	MOD	MNP	401	009		Inloopnet	Schip
11	1	MOD	MNP	401	010		Inloopbrug	Schip
12	2	MOD	MNP	401	011		Wandje + zitbank	
13	1	MOD	MNP	401	012		Glijbaan	Schip
14	1	MOD	MNP	403	001		Rebo pakket	Schip
15	1	MOD	MNP	403	002		Bordes	Schip
16	1	MOD	MNP	403	003		Wandje	Met raam
17	1	MOD	MNP	403	004		Kruipbuis	Schip
18	1	MOD	MNP	403	005		Glijstang	Schip
19	1	MOD	MNP	403	006		Terugdringstang	Schip
20	1	MOD	MNP	403	007		Reling	Schip
21	1	MOD	MNP	403	008		Klimschot	Schip
22	2	MOD	OBT	009	001		Poer Model 9	Gewicht 33,5 kg
23	1	MOD	OBT	010	001		Poermodel 10	50 kilo



Benaming
Title | Schip

Opmerking
Comment | Groot

Datum
Date | 28-8-2015

Tekening
Drawing

TOE MNP 403 001

Modules Modules

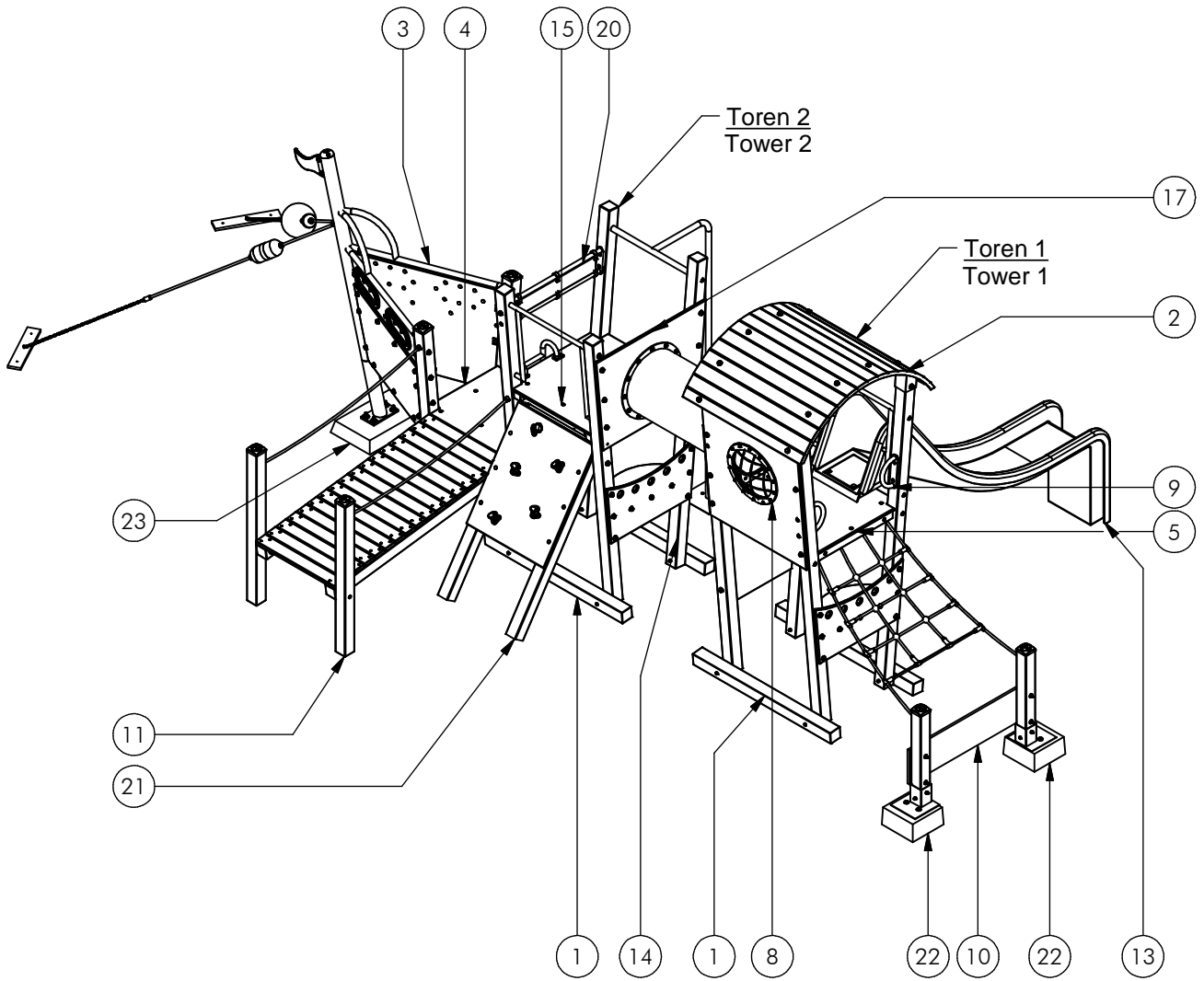

Benaming
Title | Schip

Opmerking
Comment | Groot

Datum
Date | 28-8-2015

Tekening
Drawing

TOE MNP 403 001

Modules Modules

MNPE403.001

Ship

LOGBOOK

(Onderstaand logboek kan gebruikt worden om te voldoen aan de eisen, gesteld in artikel 14 van het Warenwetbesluit Attractie- en Speeltoestellen)

Type indication	Mini Play
Product code	MNPE403.001
Name of equipment	AP Schip Groot
Maximum height of fall	1,0 m
Year of construction	2017
Certificate	63889
inspection authority	Aib Vincotte Nederland Takkebijsters 8, Breda - 4817 BL Breda
Name manufacturer	BOERplay Hyacintstraat 2 - 4255 HX Nieuwendijk Phone: +31 (0)183 40 23 66 Fax: +31 (0)183 40 35 64
name installer	_____ _____
Description of equipment	Ship
Location of equipment	_____
Data about the owner of the play equipment	
Name:	_____
Address:	_____
Postcode and town:	_____
Contact person:	_____
Telephone number:	_____
Data about the administrator of the play equipment	
Name:	_____
Address:	_____
Postcode and town:	_____
Contact person:	_____
Telephone number:	_____

LOGBOOK

Inspection and maintenance intervals



Nr.	Inspection	Maintenance	months between inspections
1	Verify equipment's stability, junctions and missing parts. Inspect bolts, screws and nuts for absence, jams, corrosion and wear.	Add missing parts, secure joints, apply missing fixing agent and replace corroded parts.	1
2	Check suspension for wear.	Replace worn parts and/or remove non-functioning parts.	1
3	Inspect rotating parts such as hinges, rolling-element bearings, etc. for wear and acceptability.	Replace worn parts and/or remove non-functioning parts.	1
4	Check wood for splinters, unacceptable damage and signs of rot. Especially at ground level.	Repair damage. Replace affected wood. Smoothen splintered wood and sharp edges.	1
5	Inspect foundation for stability, tearing and coverage.	Restore foundation and covering material.	3
6	Examine rubber and synthetic parts for wear, damage and break.	Replace original parts.	3
7	Inspect metal for corrosion and damage in the coating.	Restore any damaged coating (after removing rust and applying primer).	6
8	Check ropes, cables, chains and nets for wear and damage. Steel cables and nets which are tensioned must be checked for tension.	Replace parts where necessary. Steel cables and nets must be tensioned.	3
9	Inspect equipment for unsafe changes and additions.	Remove unsafe additions and correct unsafe changes.	1
10	Inspect safety surfaces.	Restore and repair where necessary.	1

Remarks

1. If used intensively, all points require extra attention.
2. Extreme weather conditions and locations may require a higher inspection frequency. Discuss this with the supplier.
3. Vandalism-sensitive locations require stricter inspections, possibly daily.
4. Check the terrain regularly for items that do not belong there, are unsafe or may be used wrongly. Examples are poisonous plants, glass shards, etc. Frequency depends on strain.
5. Remember that bad maintenance leads to unsafe conditions and notably faster impoverishment of the playground area.
6. Replacement parts can be ordered at the manufacturer with the part numbers on the module drawing. Drawings can be found in de user guide.
7. The impact area shall be provided with impact attenuating surface according to the specified falling height.
8. This list is conform the CEN-standard "playground equipment and surfacing NEN-EN 1176-7".

CERTIFICAAT VAN GOEDKEURING

Afgegeven door AIB-Vinçotte Nederland B.V., aangewezen bij ministeriële beschikking van het Ministerie van Volksgezondheid, Welzijn en Sport, van 29 maart 2001 onder kenmerk GZB/C&O/2162178.

Het certificaat betreft de keuring van een typekenmerkend speeltoestel.

Certificaat nr. : 63889

Afgifte datum cert. : 05 november 2007

Dossier-rapport nr. : 63889

Datum keuring : 22 juni 2007

Betreft : Inter Play

Type Nr. : 34.1.403.XXXXXX

Soort toestel : Combinatie toestel

NEN-EN 1176-1 + 3

Eigenaar - houder :

Fabrikant : Boer Speeltoestellen B.V.

Postbus 10 4255 ZG NIEUWENDIJK (NL)

Jaar van fabricage :

Leverancier : Boer Speeltoestellen B.V.

Postbus 10 4255 ZG NIEUWENDIJK (NL)

Jaar van leverantie :

Dit certificaat is onbeperkt geldig

AIB-Vinçotte Nederland B.V. gevestigd aan de Heusing 2 te Breda, verklaart dat het bovenbeschreven toestel voldoet aan de vervaardigingsvoorschriften genoemd in het Warenwet Besluit "Attractie- en Speeltoestellen"

AIB-Vinçotte Nederland B.V.

Namens het bestuur,



R. van Hirtum

Afdelingsmanager Attractie & Speeltoestellen



M. Verheijen

Inspecteur

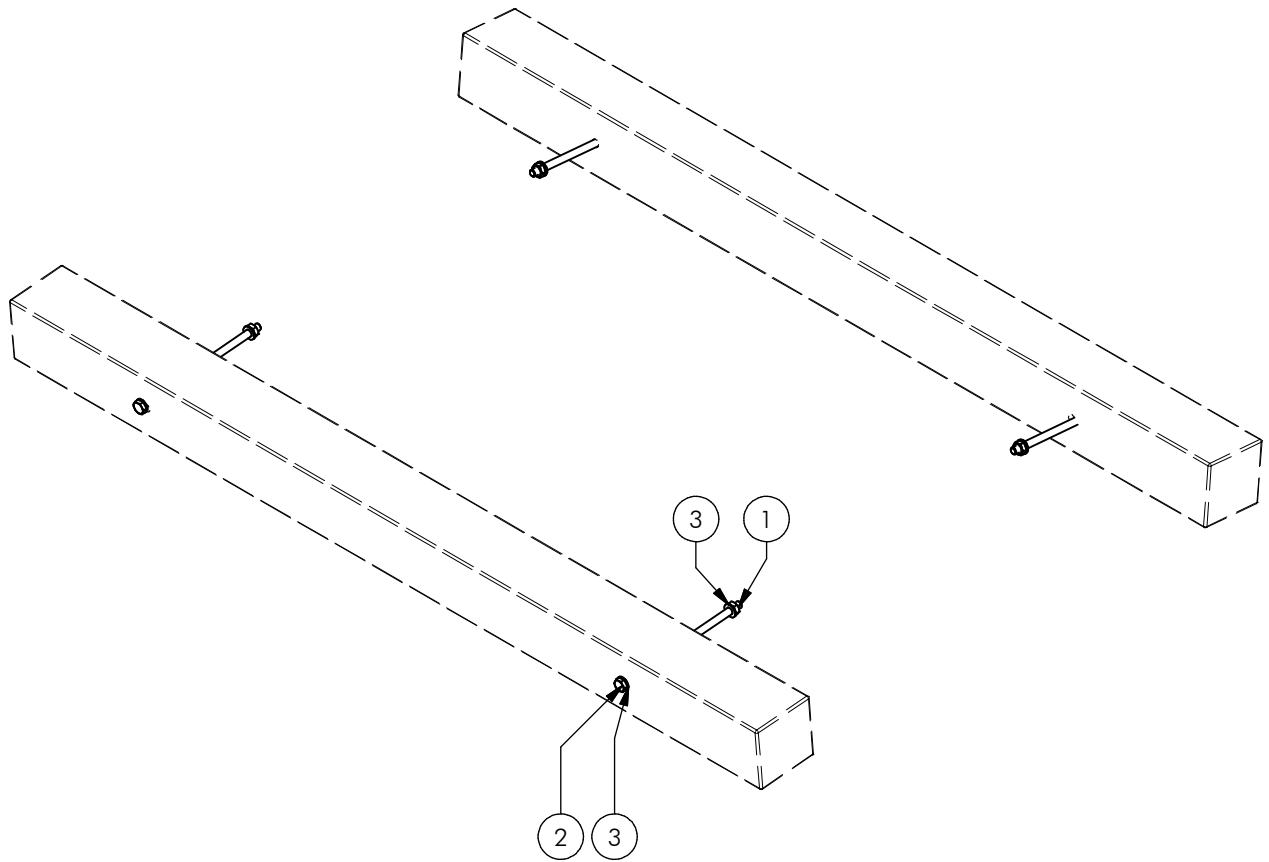

Nr	#	Type	Progr.	Volgnr	Bew.	Rev.	Benaming	Opmerking
1	8	BSV	017	010	008		Zeskantmoer	M10 - VZ 8.8
2	8	BSV	021	010	220		Zeskantbout ISO 4014	M10 x 220 - VZ 8.8
3	16	BSV	030	010	002		Sluitring	M10 - VZ 8.8



Benaming
Title Schoren

Opmerking
Comment incl. bevestiging

Datum
Date 17-4-2015

Tekening
Drawing

MOD FRP KST 080

Samenstelling module *Assembly module*

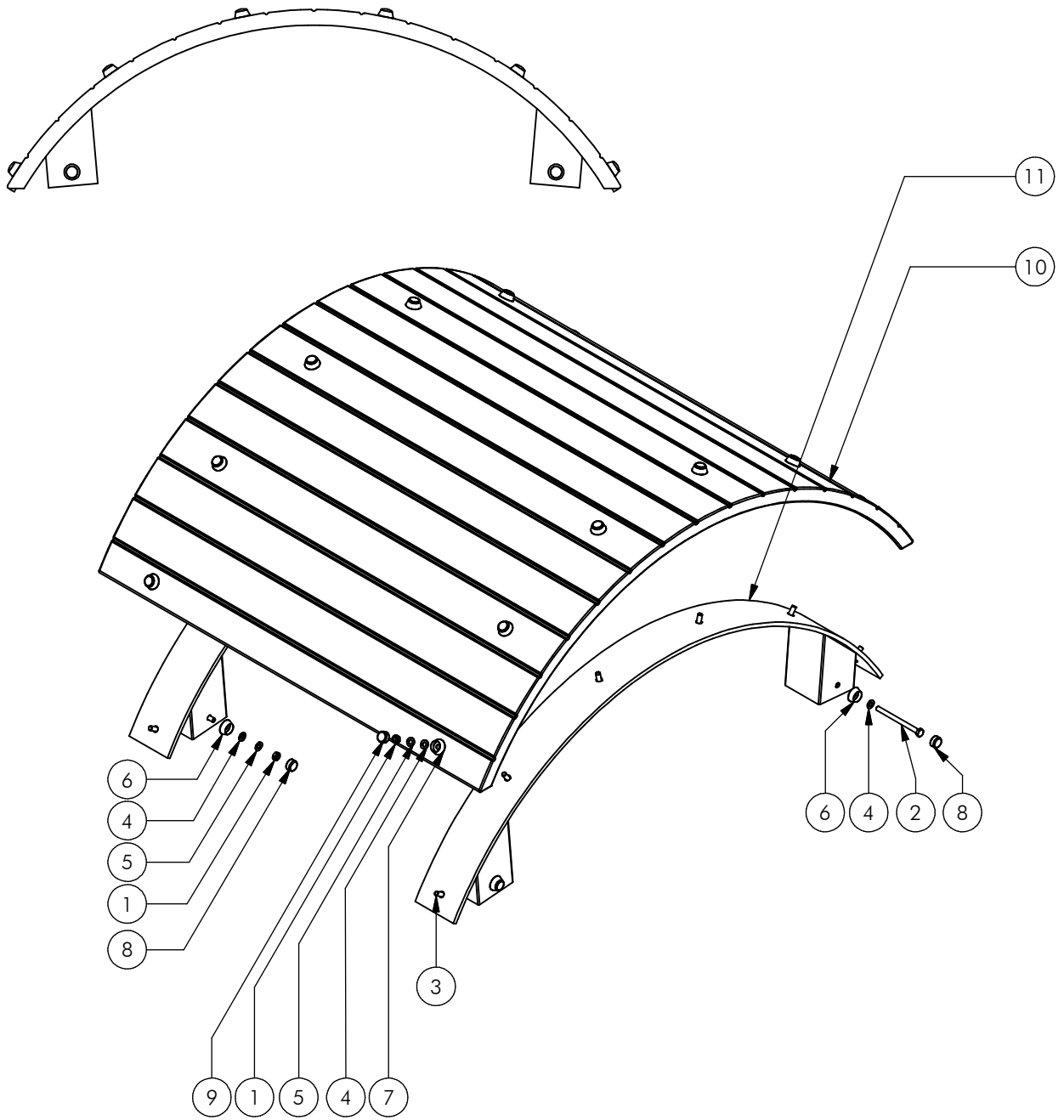

Nr	#	Type	Progr.	Volgnr	Bew.	Rev.	Benaming	Opmerking
1	16	BSV	017	010	008		Zeskantmoer	M10 - VZ 8.8
2	4	BSV	021	010	130		Zeskantbout ISO 4014	M10 x 130 - VZ 8.8
3	12	BSV	026	010	030		Slotbout	M10 x 30 - VZ 8.8
4	20	BSV	030	010	002		Sluitring	M10 - VZ 8.8
5	16	BSV	032	010	002		Veerring	M10 - VZ 8.8
6	8	KST	DON	011	090		interplay donut	zwart
7	12	KST	DON	011	030		interplay donut	rood
8	8	KST	DOP	011	090		interplay dop	zwart
9	12	KST	DOP	011	030		interplay dop	rood
10	1	POL	FRP	026	320	A	Polyester overkapping	Freeplay
11	2	SME	FRP	034	906		Daksteun	Freeplay



Benaming Title Dak
 Opmerking Comment Tractor/Trein
 Datum Date 3-6-2015

Tekening Drawing

MOD MNP 341 017

Samenstelling module Assembly module

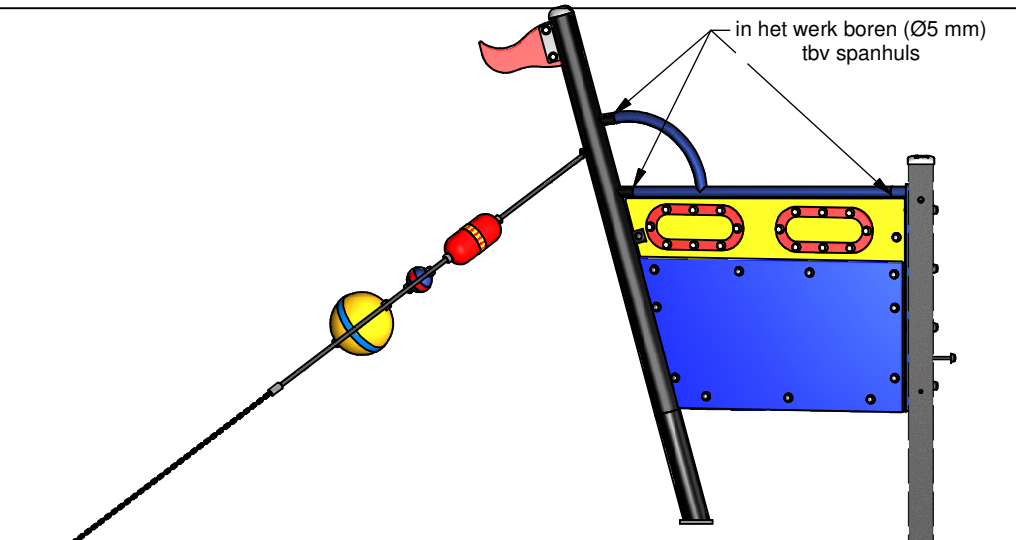
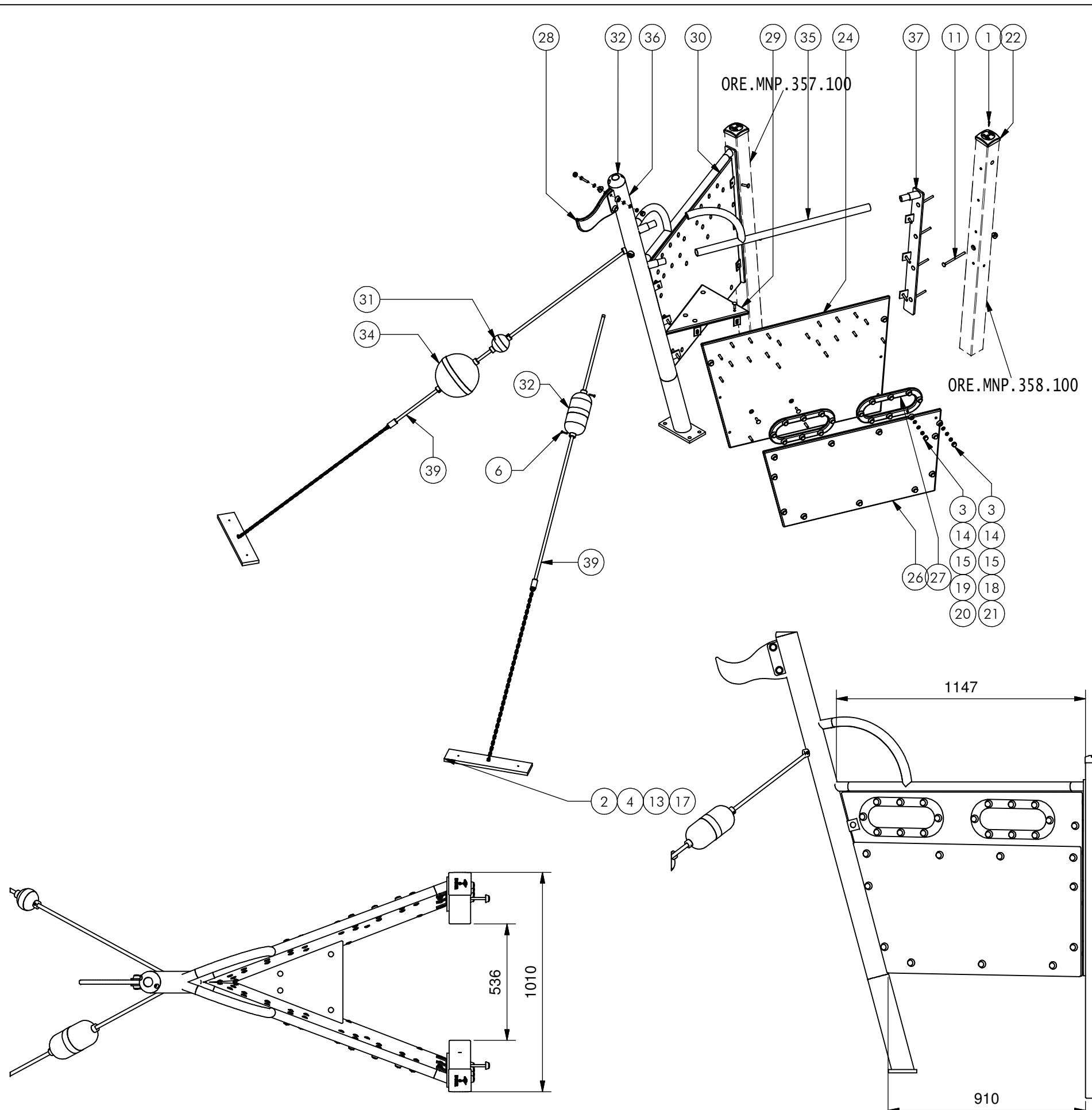

Nr.	#	Type	Progr.	Volgnr	Bew.	Rev.	Benaming	Opmerking
1	2	BSR	002	005	030		Schroef Assy	5 x 30 - RVS A2-70
2	2	BSV	017	006	005		Zeskantmoer	M6 - VZ 8.8
3	78	BSV	017	010	008		Zeskantmoer	M10 - VZ 8.8
4	2	BSV	021	006	050		Zeskantbout ISO 4014	M6 x 50 - VZ 8.8
5	2	BSV	021	010	050		Zeskantbout ISO 4014	M10 x 50 - VZ 8.8
6	8	BSV	025	006	030		Veiligheidsschroef	Pin-Torx - VZ 8.8
7	4	BSV	026	010	040		Slotbout	M10 x 40 - VZ 8.8
8	8	BSV	026	010	060		SLOTBOUT	M10x60
9	46	BSV	026	010	055		SLOTBOUT	M10x55
10	8	BSV	026	010	120		Slotbout	M10 x 120 - VZ 8.8
11	2	BSV	026	010	170		Slotbout	M10 x 170 - VZ 8.8
12	8	BSV	026	010	035		SLOTBOUT	M10x35
13	4	BSV	030	006	002		Sluitring	M6 - VZ 8.8
14	80	BSV	030	010	002		SLUITRING	M10 VZ
15	78	BSV	034	010	002		Veerring	M10 - VZ 8.8
16	6	BSV	047	005	030		Spanhuls	M5 x 30 - VZ 8.8
17	2	KST	APL	050			Ankerplaat	500x100x19
18	44	KST	DON	011	090		interplay donut	zwart
19	36	KST	DON	011	020		interplay donut M10 wit	84395000012
20	36	KST	DOP	011	020		interplay dop M10 wit	84395000014
21	44	KST	DOP	011	090		interplay dop	zwart
22	2	OME	KAP	100	916	B	Paalkap 100x100	Aluminium
23	4	OME	MNP	009	320		Hoekje model 1	
24	1	OPE	MNP	389	010	A	Romppaneel	Groot links
25	1	OPE	MNP	390	090		Romppaneel	Klein
26	1	OPE	MNP	390	050		Romppaneel	Klein
27	4	OPE	MNP	391	030		Flens Ovaal	
28	1	OPE	MNP	392	030		Vlag	
29	1	OPE	MNP	401	050		Boegzijte	Schip
30	1	OPE	MNP	490	010		Romppaneel	Groot rechts
31	1	SMD	MNP	019	001		Poly bol	Ø100
32	1	SMD	MNP	020	001		Poly Bol	Ovaal 120
33	1	SMD	SLP	001	906		Paalkap	Stellar play/Technoplay
33.1	1	OME	SLP	057	ALU		Dop paalkap	Stellar play/Techno play
33.2	1	OME	SLP	058	ALU		Paalkap	Stellar play/Techno play
33.3	1	BSV	027	010	065		Cilinderkop bout	M10 x 65 - VZ 8.8
33.4	1	BSV	017	010	008		Zeskantmoer	M10 - VZ 8.8
34	1	SMD	SLP	006	001		Bol diameter 250 met busen	Stellar Play
35	2	SME	MNP	102	502		Rompbuis	Schip
36	1	SME	MNP	103	905		Boegbuis	Schip
37	1	SME	MNP	104	502		Strip romp	Schip
38	1	SME	MNP	105	502		Strip romp	Schip
39	2	SNT	MNP	007	090		Afmeerkabel	

Benaming Boeg

Opmerking Schip

Datum 18-8-2015

Tekening MOD MNP 401 002 A

Drawing Samenstelling module Assembly module

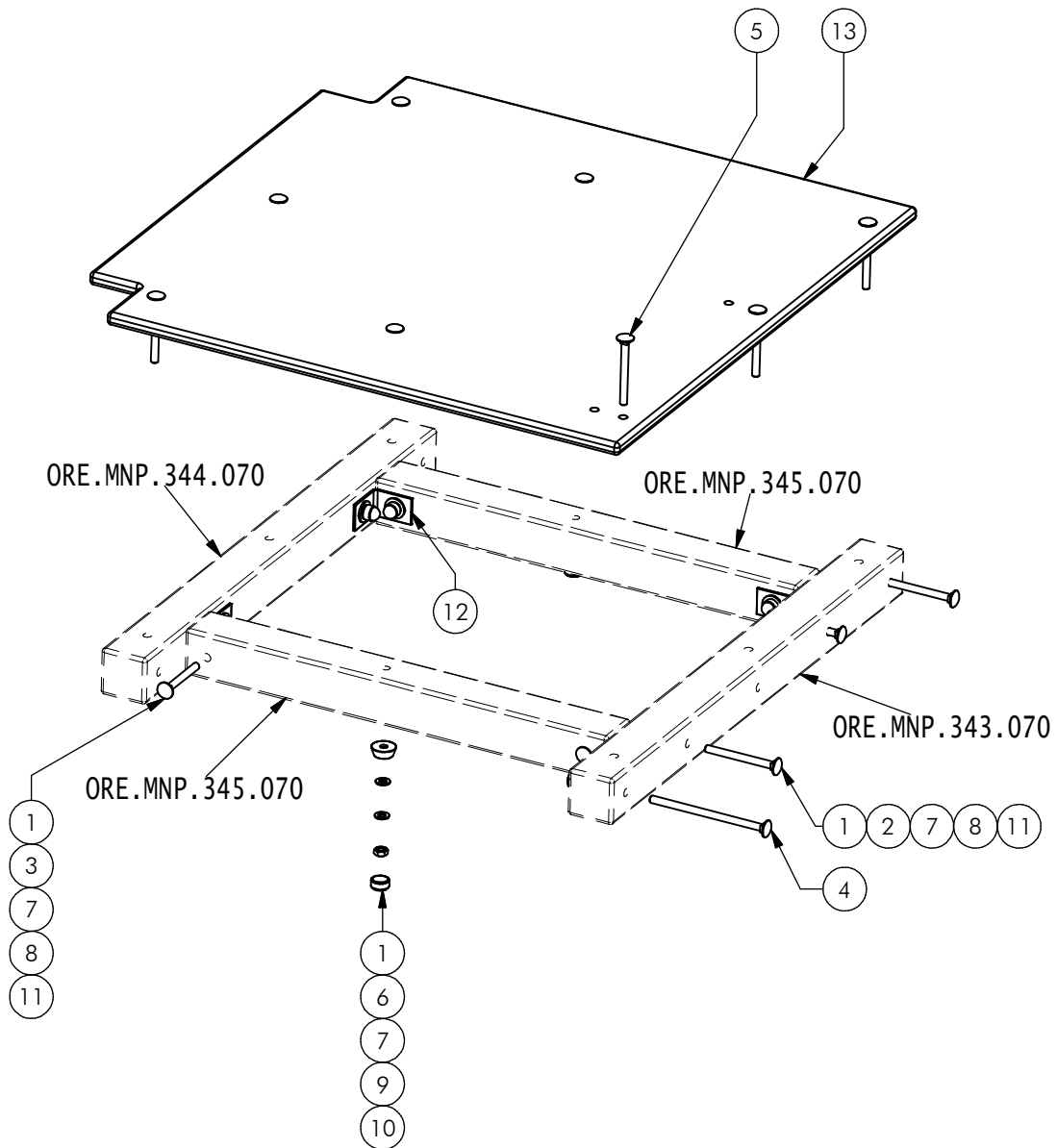

Nr	#	Type	Progr.	Volgnr	Bew.	Rev.	Benaming	Opmerking
1	18	BSV	017	010	008		Zeskantmoer	M10 - VZ 8.8
2	2	BSV	026	010	110		Slotbout	M10 x 110 - VZ 8.8
3	6	BSV	026	010	090		Slotbout	M10 x 90 - VZ 8.8
4	2	BSV	026	010	180		Slotbout	M10 x 180 - VZ 8.8
5	8	BSV	026	010	100		Slotbout	M10 x 100 - VZ 8.8
6	10	BSV	030	010	002		Sluitering	M10 - VZ 8.8
7	18	BSV	032	010	002		Veerring	M10 - VZ 8.8
8	8	BSV	035	010	030		Carrosseriering	M10 x 30 - VZ 8.8
9	10	KST	DON	323	090		interplay donut	zwart
10	10	KST	DOP	323	090		interplay dop	zwart
11	8	KST	ZKD	010	021		Afdekdop zeskantbout	M10 zwart
12	4	OME	MNP	009	320		Hoekje model 1	
13	1	OPE	MNP	393	030		Vlonderplaat	Schip



Benaming
Title Vlonder

Opmerking
Comment Schip

Datum
Date 20-8-2015

Tekening
Drawing

MOD MNP 401 003

Samenstelling module Assembly module

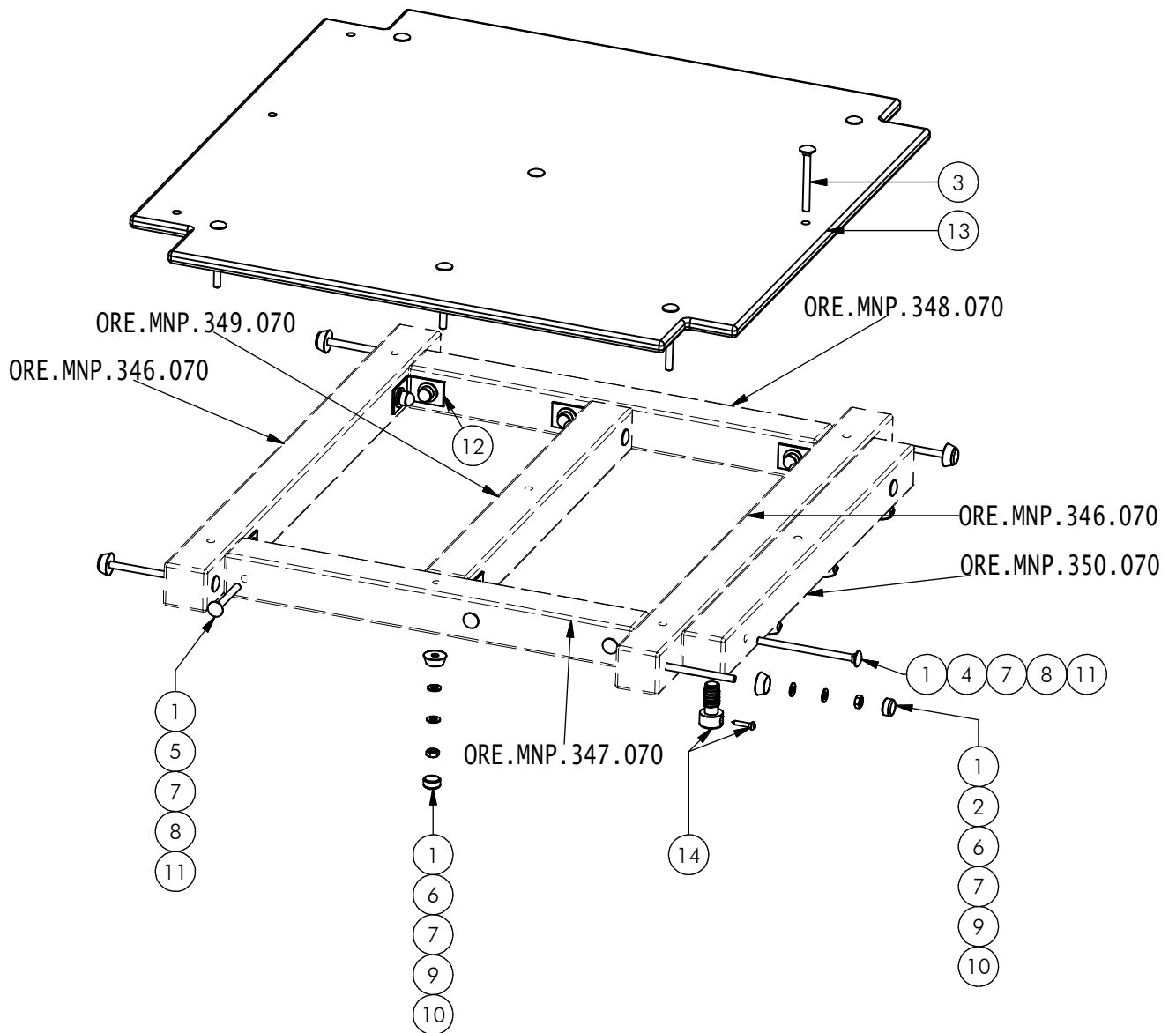

Nr	#	Type	Progr.	Volgnr	Bew.	Rev.	Benaming	Opmerking
1	23	BSV	017	010	008		Zeskantmoer	M10 - VZ 8.8
2	4	BSV	026	010	180		Slotbout	M10 x 180 - VZ 8.8
3	7	BSV	026	010	100		Slotbout	M10 x 100 - VZ 8.8
4	2	BSV	026	010	160		Slotbout	M10 x 160 - VZ 8.8
5	10	BSV	026	010	090		Slotbout	M10 x 90 - VZ 8.8
6	11	BSV	030	010	002		Sluitring	M10 - VZ 8.8
7	23	BSV	032	010	002		Veerring	M10 - VZ 8.8
8	12	BSV	035	010	030		Carrosseriering	M10 x 30 - VZ 8.8
9	11	KST	DON	323	090		interplay donut	zwart
10	11	KST	DOP	323	090		interplay dop	zwart
11	12	KST	ZKD	010	021		Afdekdop zeskantbout	M10 zwart
12	6	OME	MNP	009	320		Hoekje model 1	
13	1	OPE	MNP	394	030		Bordesplaat	Schip
14	4	SMD	BUS	002	RVS		Bus + VZ schroef	Touw 16 mm



Benaming
Title Bordes

Opmerking
Comment Schip

Datum
Date 20-8-2015

Tekening
Drawing

MOD MNP 401 004

Samenstelling module Assembly module

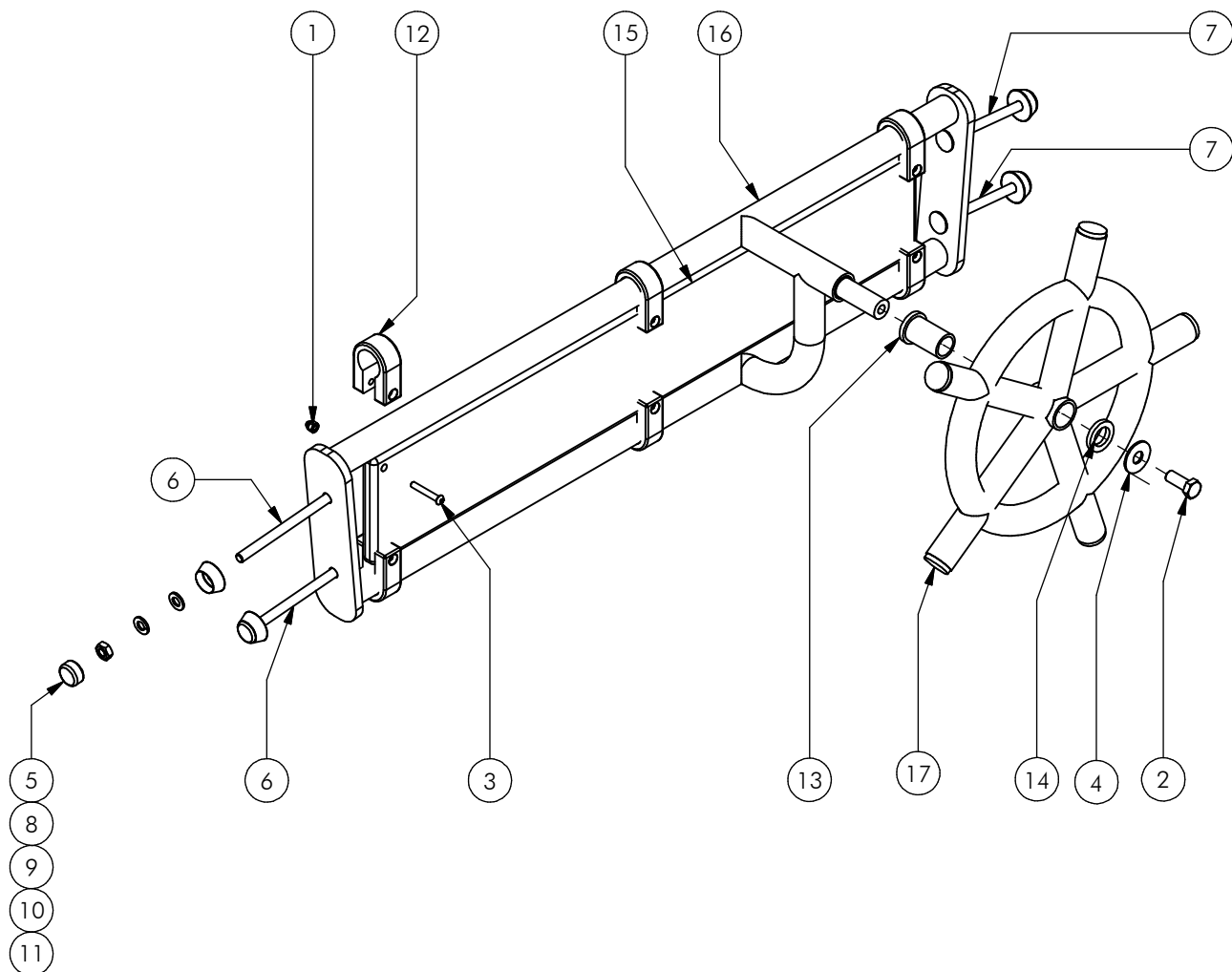

Nr	#	Type	Progr.	Volgnr	Bew.	Rev.	Benaming	Opmerking
1	6	BSR	011	006	012		Borgdopmoer	M6 - RVS A2-70
2	1	BSR	021	012	030		Zeskantbout	M12 x 30 - RVS A2-70
3	6	BSR	025	006	040		Veiligheids Bout	Pin-Torx - RVS A2-70
4	1	BSR	035	012	035		Carrosserie ring	M12 - RVS A2-70
5	4	BSV	017	010	008		Zeskantmoer	M10 - VZ 8.8
6	2	BSV	026	010	140		Slotbout	M10 x 140 - VZ 8.8
7	2	BSV	026	010	120		Slotbout	M10 x 120 - VZ 8.8
8	4	BSV	030	010	002		Sluitring	M10 - VZ 8.8
9	4	BSV	034	010	002		Veerring	M10 - VZ 8.8
10	4	KST	DON	011	090		interplay donut	zwart
11	4	KST	DOP	011	090		interplay dop	zwart
12	6	KST	KLM	032	030		Klembeugel rood 32mm	80095001005
13	1	KST	MNP	147	PA6		Kunststof bus	Stuurrad
14	1	KST	RNG	022	035		Kunststof Ring	22 x 35 dikte 5
15	1	OPE	MNP	388	010		Leuning recht	Stuurzijde
16	1	SME	MNP	100	502	A	Leuning stuurwiel	Schip
17	1	SME	MNP	101	905		Stuurwiel	schip



Benaming | Stuur
 Title
 Opmerking | Schip
 Comment
 Datum | 26-8-2015
 Date

Tekening
 Drawing

MOD MNP 401 005 A
 Samenstelling module *Assembly module*

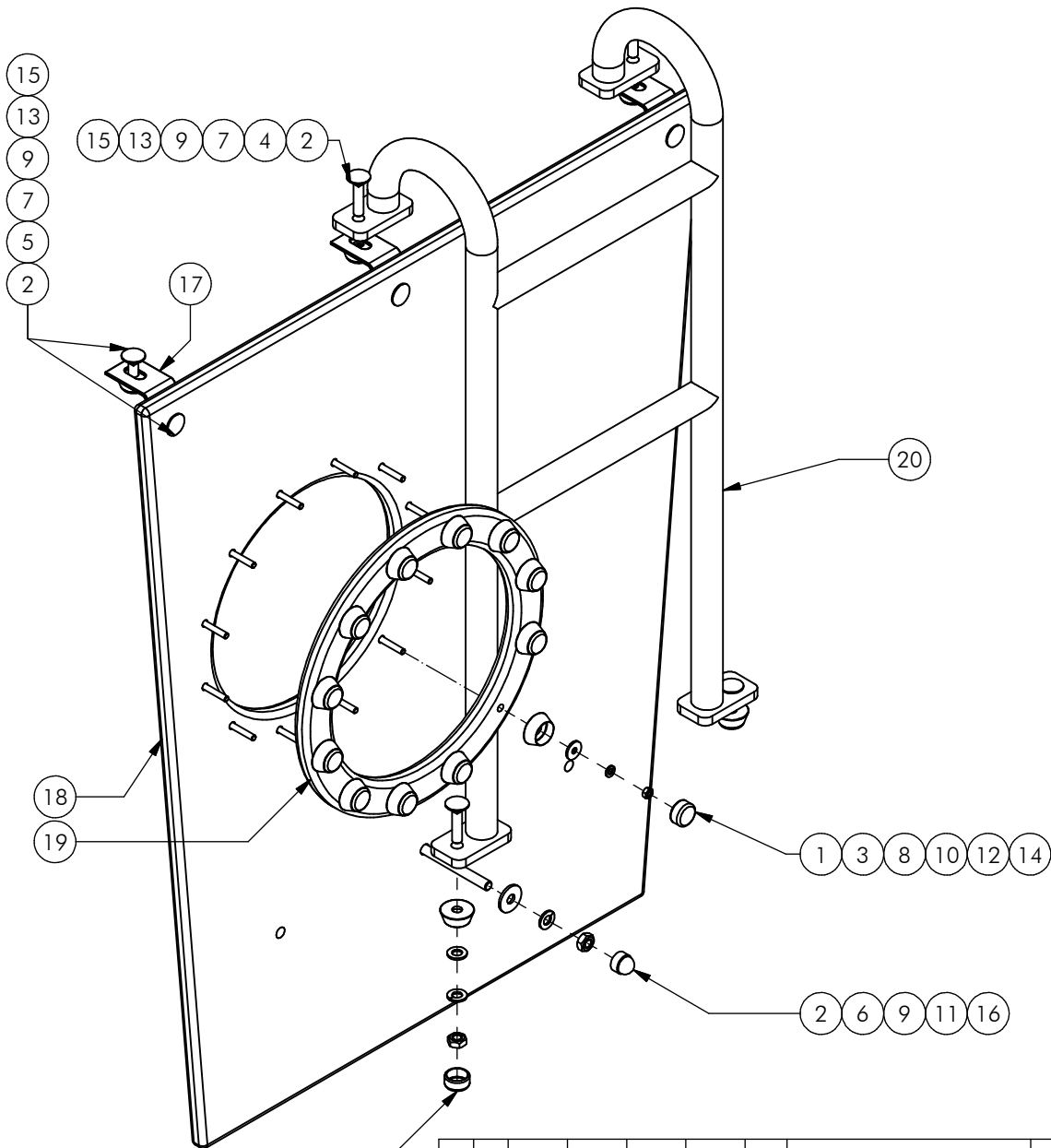

Nr	#	Type	Progr.	Volgnr	Bew.	Rev.	Benaming	Opmerking
1	12	BSV	017	006	005		Zeskantmoer	M6 - VZ 8.8
2	9	BSV	017	010	008		Zeskantmoer	M10 - VZ 8.8
3	12	BSV	026	006	050		Slotbout	M6 x 50 Verzinkt
4	4	BSV	026	010	045		Slotbout	M10 x 45 - VZ 8.8
5	4	BSV	026	010	035		Slotbout	M10 x 35 - VZ 8.8
6	1	BSV	026	010	110		Slotbout	M10 x 110 - VZ 8.8
7	8	BSV	030	010	002		Sluitring	M10 - VZ 8.8
8	12	BSV	032	006	002		Veerring	M6 - VZ 8.8
9	9	BSV	032	010	002		Veerring	M10 - VZ 8.8
10	12	BSV	035	006	020		CARROSSIERIERING	M6 x 20 - VZ 8.8
11	1	BSV	035	010	030		Carrossieriering	M10 x 30 - VZ 8.8
12	12	KST	DON	011	020		interplay donut M10 wit	84395000012
13	8	KST	DON	323	090		interplay donut	zwart
14	12	KST	DOP	011	020		interplay dop M10 wit	84395000014
15	8	KST	DOP	323	090		interplay dop	zwart
16	1	KST	ZKD	010	021		Afdekdop zeskantbout	M10 zwart
17	3	OME	MNP	009	320		Hoekje model 1	
18	1	OPE	MNP	395	050		Wand met raam	Schip
19	1	OPE	MNP	396	030		Kozijn	Schip
20	1	SME	MNP	106	906		Trap	Schip



Benaming Title Wandje
 Opmerking Comment Met raam
 Datum Date 26-8-2015

Tekening Drawing

MOD MNP 401 006

Samenstelling module Assembly module

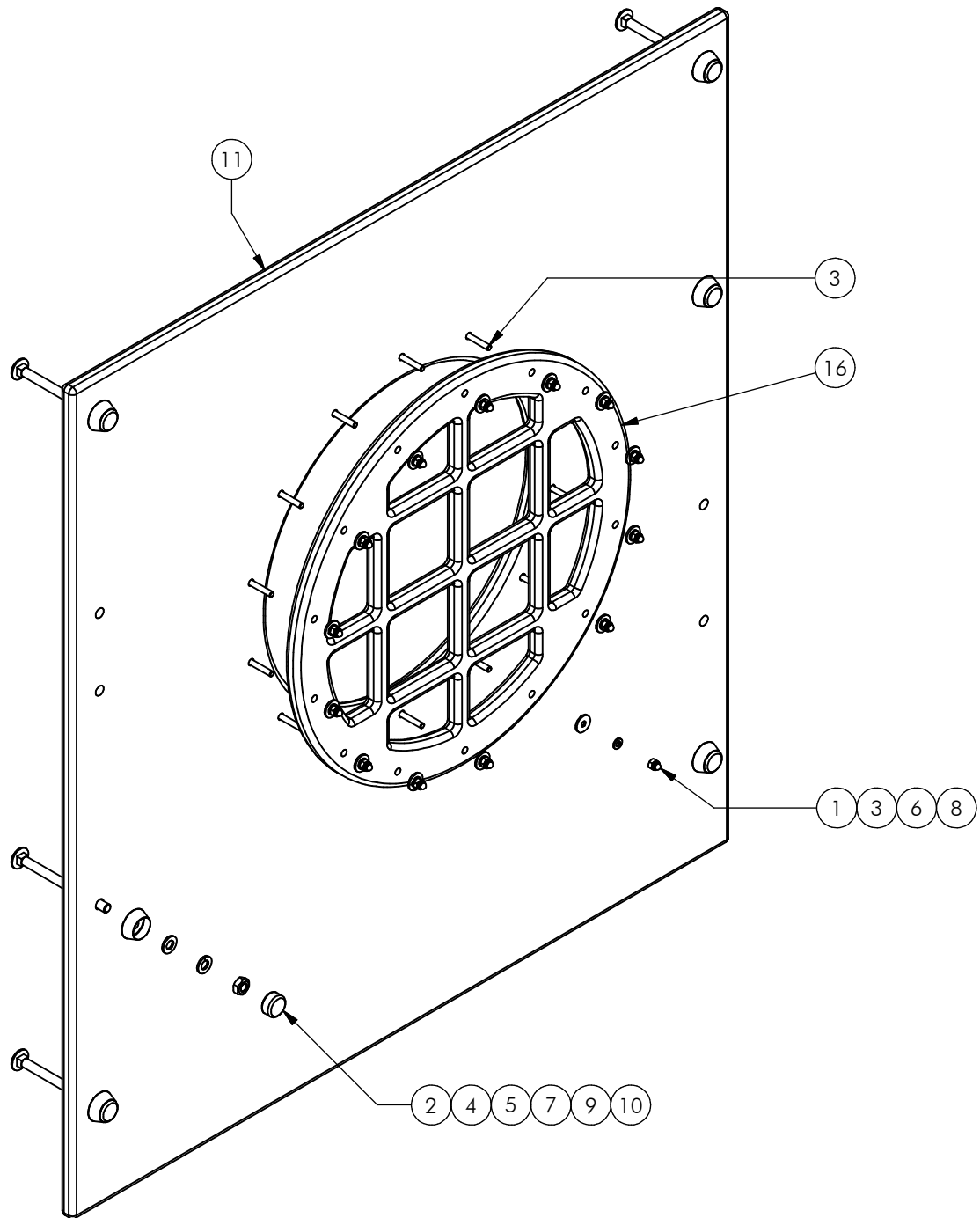

Nr	#	Type	Progr.	Volgnr	Bew.	Rev.	Benaming	Opmerking
1	14	BSV	012	006	012		Dopmoer	M6 - VZ 8.8
2	6	BSV	017	010	008		Zeskantmoer	M10 - VZ 8.8
3	14	BSV	026	006	050		Slotbout	M6 x 50 Verzinkt
4	6	BSV	026	010	130		Slotbout	M10 x 130 - VZ 8.8
5	6	BSV	030	010	002		Sluistring	M10 - VZ 8.8
6	14	BSV	034	006	002		Veerring	M6 - VZ 8.8
7	6	BSV	032	010	002		Veerring	M10 - VZ 8.8
8	14	BSV	035	006	020		CARROSSERIERING	M6 x 20 - VZ 8.8
9	6	KST	DON	011	090		interplay donut	zwart
10	6	KST	DOP	011	090		interplay dop	zwart
11	1	OPE	MNP	398	010		Tralievensterpaneel	Schip
16	1	OPE	MNP	487	050		Tralievenster	Ø500



Benaming
Title | Wand

Opmerking
Comment | Tralievenster

Datum
Date | 26-8-2015

Tekening
Drawing

MOD MNP 401 007 A
 Samenstelling module Assembly module

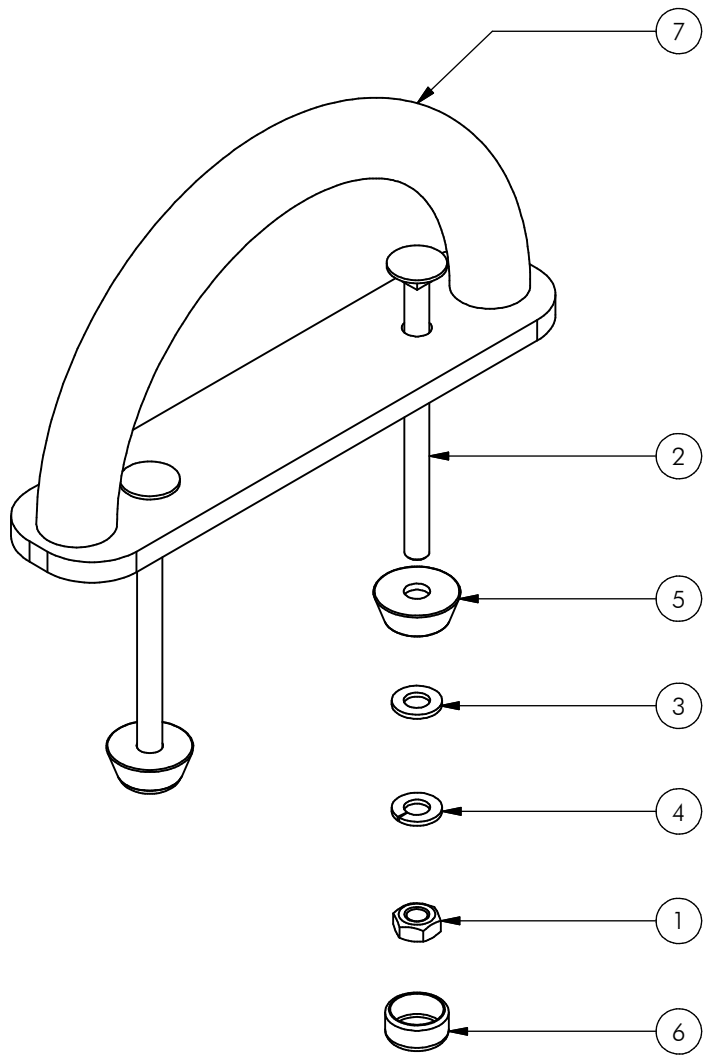

Nr	#	Type	Progr.	Volgnr	Bew.	Rev.	Benaming	Opmerking
1	2	BSV	017	010	008		Zeskantmoer	M10 - VZ 8.8
2	2	BSV	026	010	140		Slotbout	M10 x 140 - VZ 8.8
3	2	BSV	030	010	002		Sluitring	M10 - VZ 8.8
4	2	BSV	032	010	002		Veerring	M10 - VZ 8.8
5	2	KST	DON	323	090		interplay donut	zwart
6	2	KST	DOP	323	090		interplay dop	zwart
7	1	SME	MNP	099	906		Handgreep	Schip



Benaming Title Handgreep
 Opmerking Comment Schip
 Datum Date 21-8-2015

Tekening Drawing

MOD MNP 401 008

Samenstelling module Assembly module

ORE.MNP.352.100

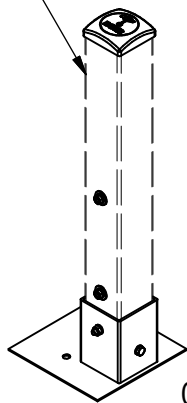

ORE.MNP.352.100

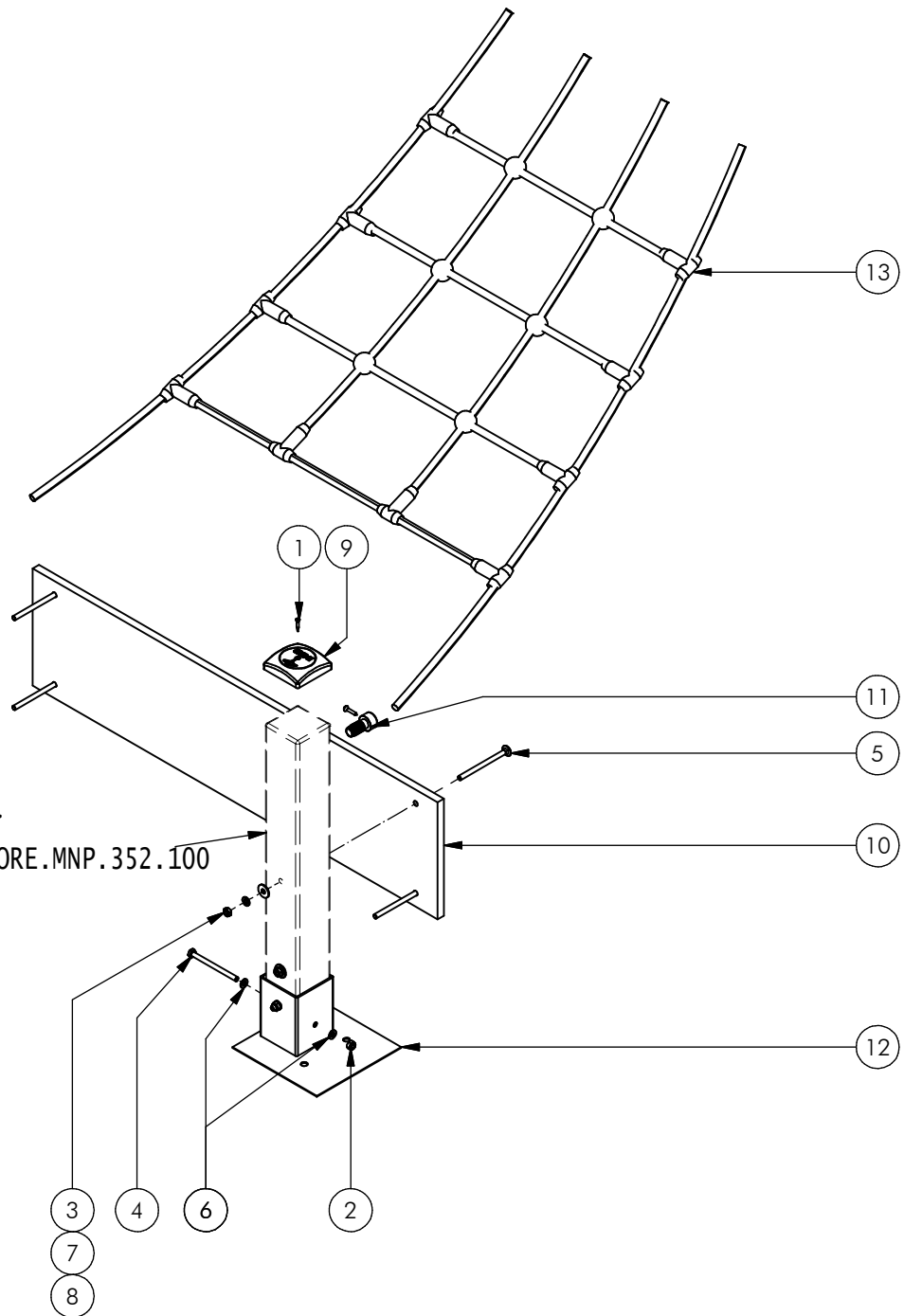

Nr	#	Type	Progr.	Volgnr	Bew.	Rev.	Benaming	Opmerking
1	2	BSR	002	005	030		Schroef Assy	5 x 30 - RVS A2-70
2	4	BSV	010	010	010		Borgmoer	M10 - VZ 8.8
3	4	BSV	017	010	008		Zeskantmoer	M10 - VZ 8.8
4	4	BSV	021	010	130		Zeskantbout ISO 4014	M10 x 130 - VZ 8.8
5	4	BSV	026	010	140		Slotbout	M10 x 140 - VZ 8.8
6	8	BSV	030	010	002		Sluitring	M10 - VZ 8.8
7	4	BSV	032	010	002		Veerring	M10 - VZ 8.8
8	4	BSV	035	010	030		Carrosseriering	M10 x 30 - VZ 8.8
9	2	OME	KAP	100	916	B	Paalkap 100x100	Aluminium
10	1	OPE	MNP	399	XXX		Grondplaat	
11	2	SMD	BUS	002	RVS		Bus + VZ schroef	Touw 16 mm
12	2	SME	MNP	109	905		Grondpot	100x100
13	1	SNT	MNP	008	030		Inloopnet	Schip



Benaming Title Inloopnet
 Opmerking Comment Schip
 Datum Date 26-8-2015

Tekening Drawing

MOD MNP 401 009

Samenstelling module Assembly module

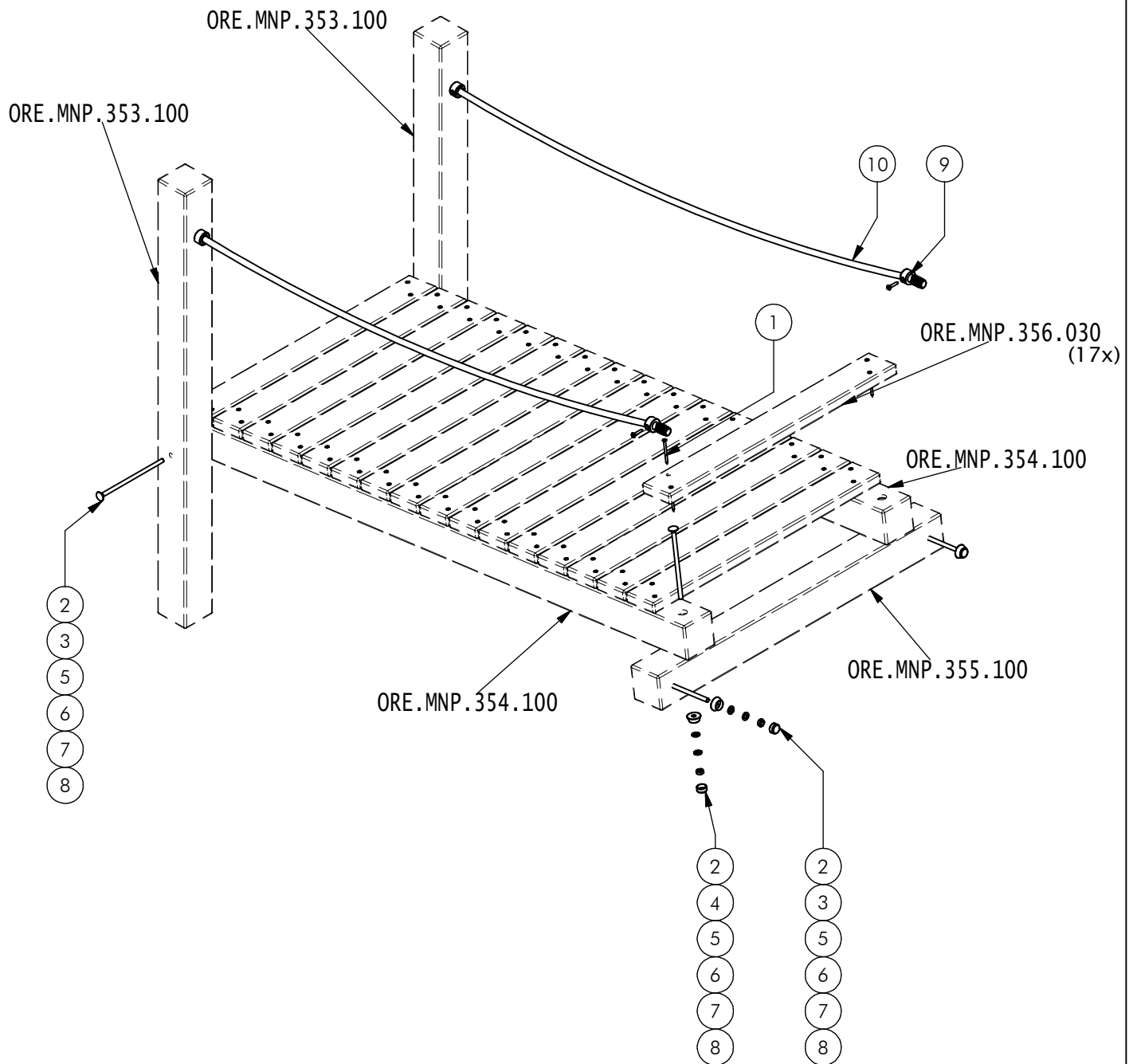

Nr	#	Type	Progr.	Volgnr	Bew.	Rev.	Benaming	Opmerking
1	68	BSV	004	005	070		Schroef verz.	5 x70 - VZ 8.8
2	6	BSV	017	010	008		Zeskantmoer	M10 - VZ 8.8
3	4	BSV	026	010	220		Slotbout	M10 x 220 - VZ 8.8
4	2	BSV	026	010	180		Slotbout	M10 x 180 - VZ 8.8
5	6	BSV	030	010	002		Sluitring	M10 - VZ 8.8
6	6	BSV	032	010	002		Veerring	M10 - VZ 8.8
7	6	KST	DON	323	090		interplay donut	zwart
8	6	KST	DOP	323	090		interplay dop	zwart
9	4	SMD	BUS	002	RVS		Bus + VZ schroef	Touw 16 mm
10	2	SNT	MNP	009	030		Leuningkabel	Schip



Benaming
Title Inloopbrug

Opmerking
Comment Schip

Datum
Date 24-8-2015

Tekening
Drawing

MOD MNP 401 010

Samenstelling module Assembly module

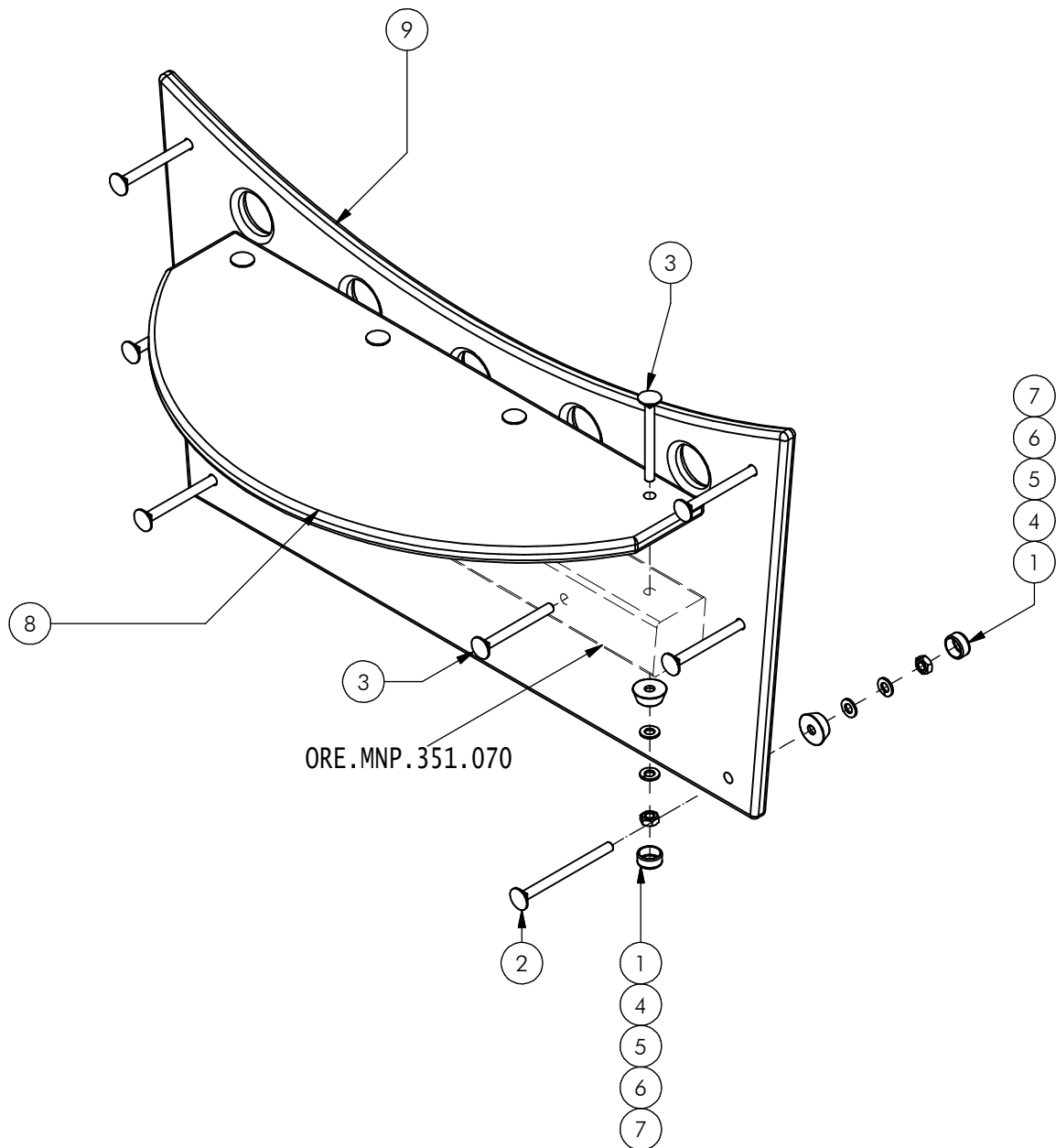

ORE.MNP.351.070

Nr	#	Type	Progr.	Volgnr	Bew.	Rev.	Benaming	Opmerking
1	13	BSV	017	010	008		Zeskantmoer	M10 - VZ 8.8
2	6	BSV	026	010	130		Slotbout	M10 x 130 - VZ 8.8
3	7	BSV	026	010	100		Slotbout	M10 x 100 - VZ 8.8
4	13	BSV	030	010	002		Sluitring	M10 - VZ 8.8
5	13	BSV	032	010	002		Veerring	M10 - VZ 8.8
6	13	KST	DON	323	090		interplay donut	zwart
7	13	KST	DOP	323	090		interplay dop	zwart
8	1	OPE	MNP	397	010		Zitbank	Schip
9	1	OPE	MNP	400	030		Rugleuning zitbank	



Benaming
Title Wandje + zitbank

Opmerking
Comment

Datum
Date 24-8-2015

Tekening
Drawing

MOD MNP 401 011

Samenstelling module Assembly module

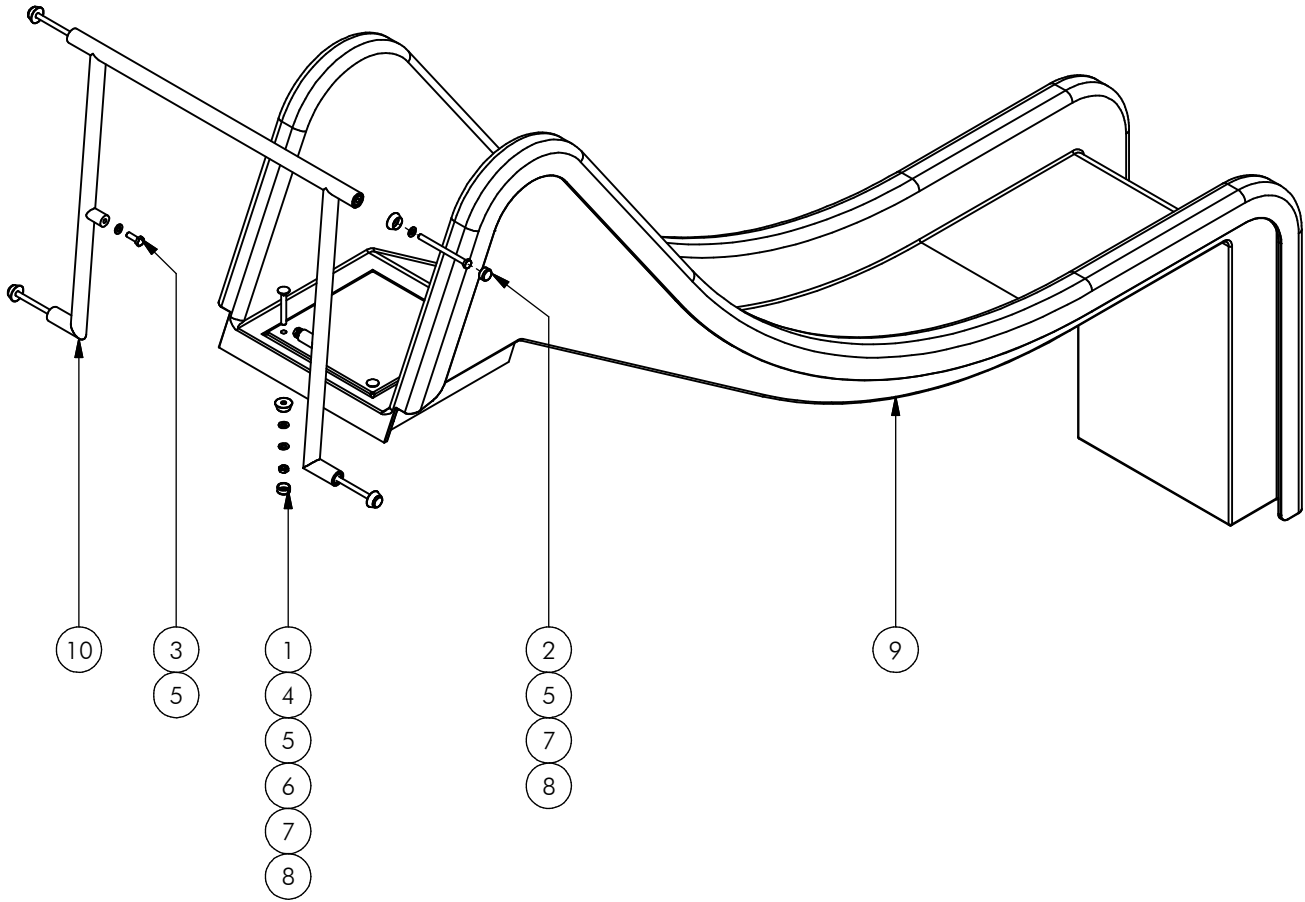

Nr	#	Type	Progr.	Volgnr	Bew.	Rev.	Benaming	Opmerking
1	2	BSV	017	010	008		Zeskantmoer	M10 - VZ 8.8
2	4	BSV	021	010	130		Zeskantbout ISO 4014	M10 x 130 - VZ 8.8
3	2	BSV	021	010	030		ZESKANTBOUT	M10 x 30
4	2	BSV	026	010	080		Slotbout	M10x80
5	8	BSV	030	010	002		Sluitring	M10 - VZ 8.8
6	2	BSV	034	010	002		Veerring	M10 - VZ 8.8
7	6	KST	DON	011	090		interplay donut	zwart
8	6	KST	DOP	011	090		interplay dop	zwart
9	1	POL	MNP	008	502		Glijbaan	Polyester
10	1	SME	MNP	108	502		Terugdringstang	



Benaming
Title | Glijbaan

Opmerking
Comment | Schip

Datum
Date | 27-8-2015

Tekening
Drawing

MOD MNP 401 012

Samenstelling module Assembly module

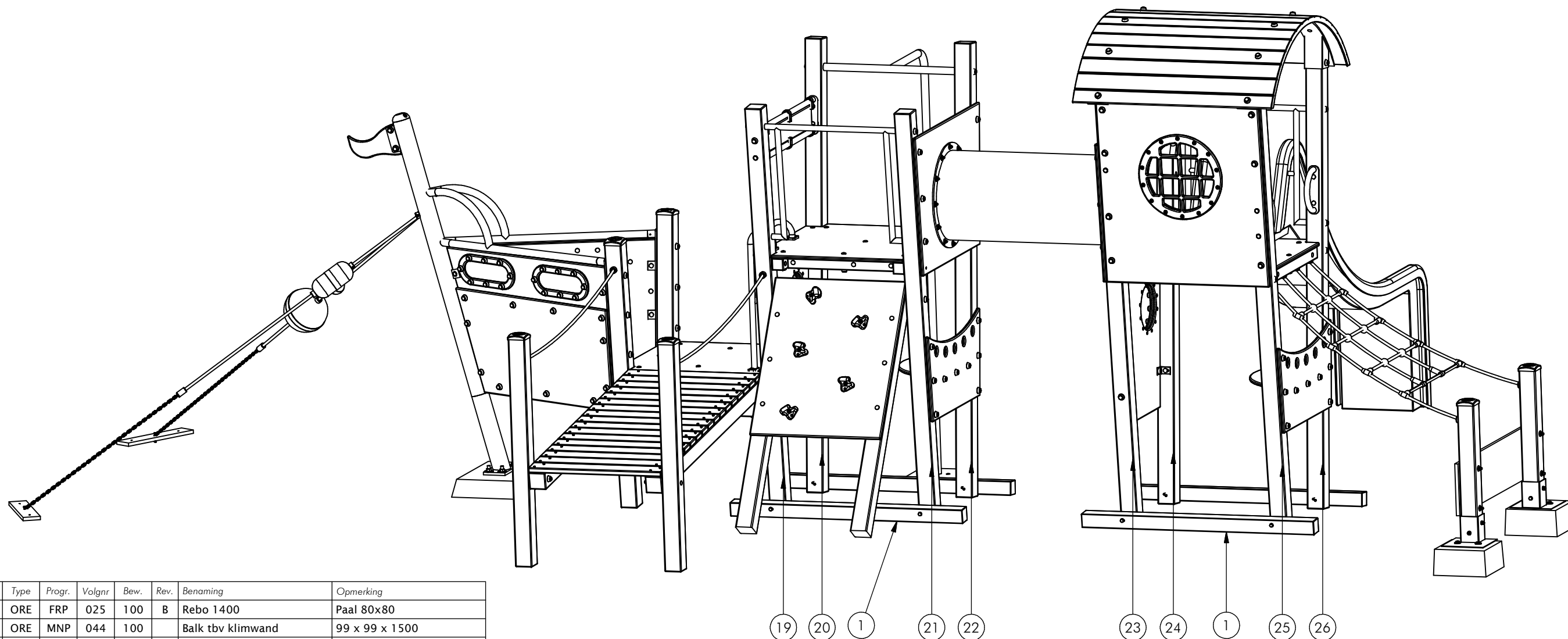

Nr	#	Type	Progr.	Volgnr	Bew.	Rev.	Benaming	Opmerking
1	4	ORE	FRP	025	100	B	Rebo 1400	Paal 80x80
2	2	ORE	MNP	044	100		Balk tbv klimwand	99 x 99 x 1500
3	1	ORE	MNP	343	070		Rebo 848	Paal 70x70
4	1	ORE	MNP	344	070		Rebo 848	Paal 70x70
5	2	ORE	MNP	345	070		Rebo 660	Paal 70x70
6	4	ORE	MNP	346	070		Rebo 960	Paal 70x70
7	2	ORE	MNP	347	070		Rebo 660	Paal 70x70
8	2	ORE	MNP	348	070		Rebo 660	Paal 70x70
9	2	ORE	MNP	349	070		Rebo 680	Paal 70x70
10	1	ORE	MNP	350	070		Rebo 780	Paal 70x70
11	2	ORE	MNP	351	070		Rebo 674	Paal 70x70
12	2	ORE	MNP	352	100		Rebo 800	Paal 99x99
13	2	ORE	MNP	353	100		Rebo 1325	Paal 99x99
14	2	ORE	MNP	354	100		Rebo 1780	Paal 99x99
15	1	ORE	MNP	355	100		Rebo 1000	Paal 99x99
16	17	ORE	MNP	356	030		Rebo 800	Plank 100x30
17	1	ORE	MNP	357	100		Rebo 1560	Paal 99x99
18	1	ORE	MNP	358	100		Rebo 1560	Paal 99x99
19	1	ORE	MNP	359	100		Rebo 2400	Paal 99x99
20	1	ORE	MNP	360	100		Rebo 2600	Paal 99x99
21	1	ORE	MNP	361	100		Rebo 2400	Paal 99x99
22	1	ORE	MNP	362	100		Rebo 2600	Paal 99x99
23	1	ORE	MNP	363	100		Rebo 2600	Paal 99x99
24	1	ORE	MNP	364	100		Rebo 2600	Paal 99x99
25	1	ORE	MNP	365	100		Rebo 2600	Paal 99x99
26	1	ORE	MNP	366	100		Rebo 2600	Paal 99x99
27	1	ORE	MNP	367	030		Rebo 790	Plank 100x30
13	1	KST	MNP	147	PA6		Kunststof bus	Stuurrad



Benaming Title Rebo pakket
 Opmerking Comment Schip
 Datum Date 31-8-2015

Tekening Drawing

MOD MNP 403 001
 Samenstelling module Assembly module

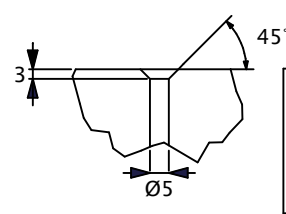
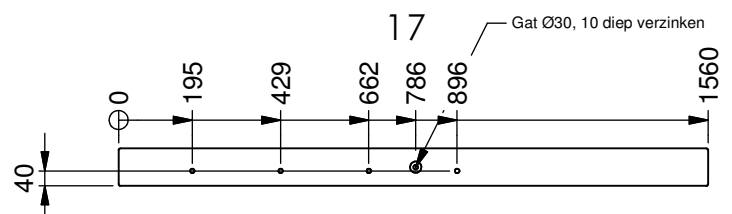
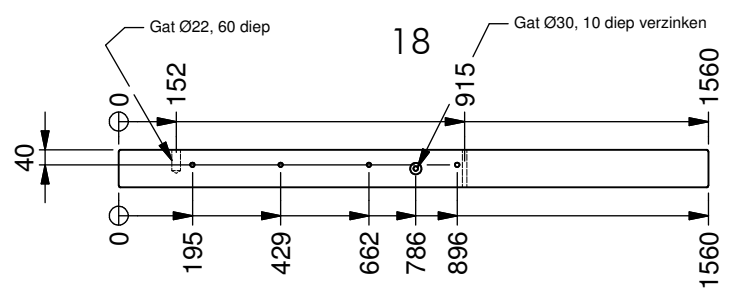
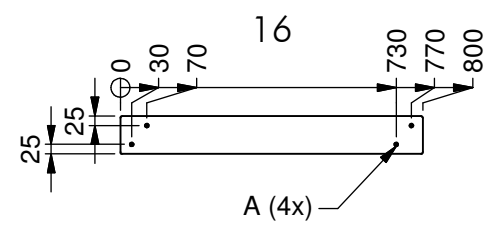
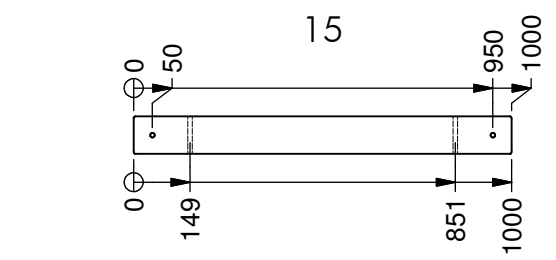
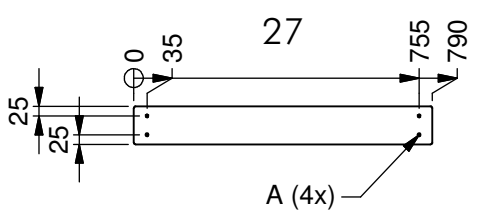
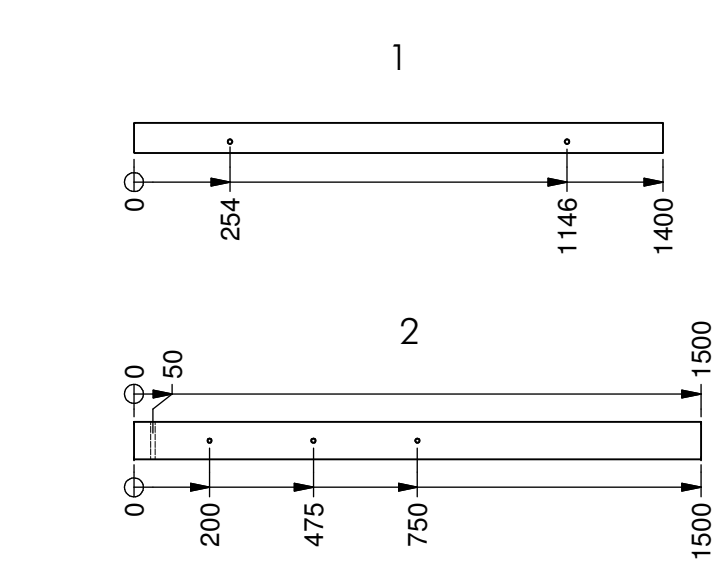

All holes Ø12 unless otherwise stated.
 All holes pierce unless otherwise stated.
 All the holes in the heart of the post, unless otherwise stated.
 Alle gaten Ø12 tenzij anders vermeld.
 Alle gaten doorboren tenzij anders vermeld.
 Alle gaten in hart van de paal tenzij anders vermeld.

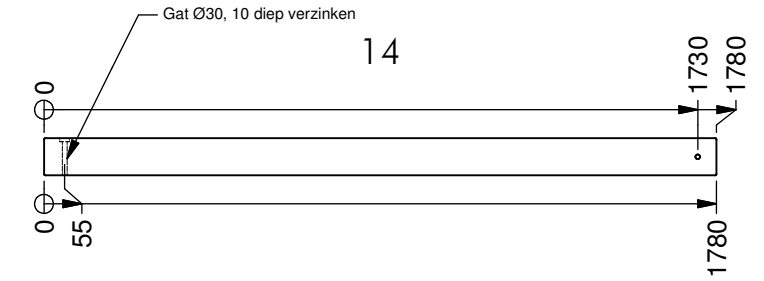
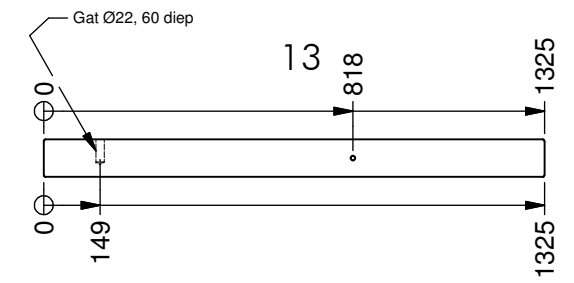
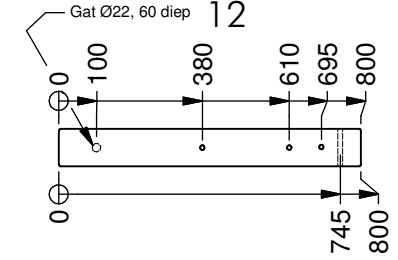
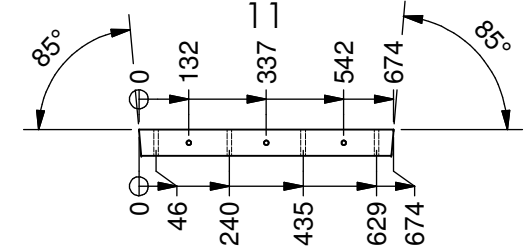
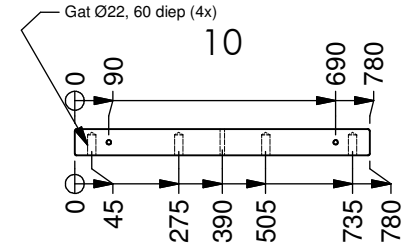
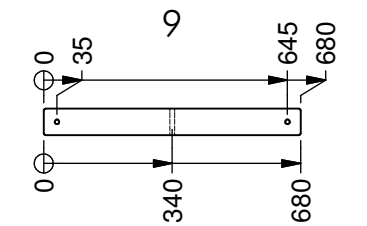
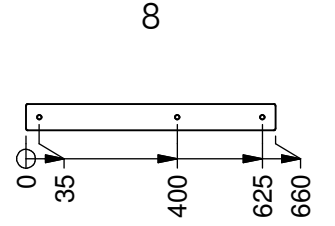
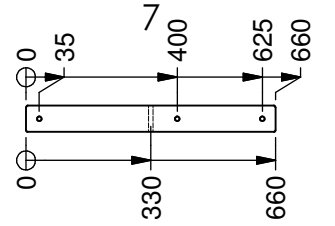
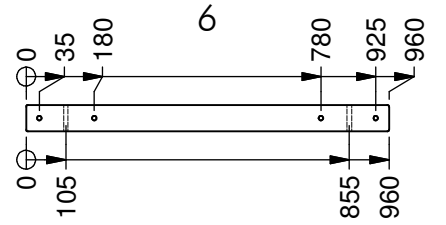
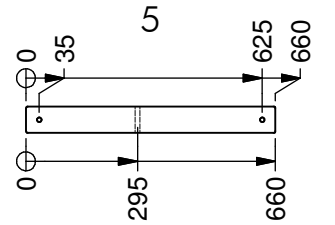
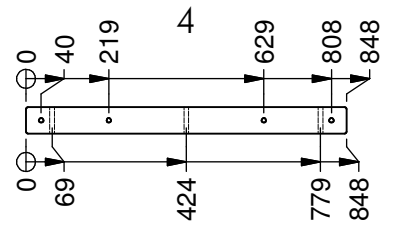
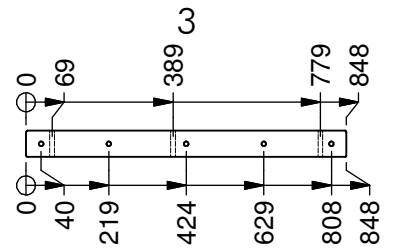

Benaming Rebo pakket
 Opmerking Schip
 Datum 31-8-2015

Tekening Drawing

MOD MNP 403 001

Zaag- en boorstaat Cut and drill table

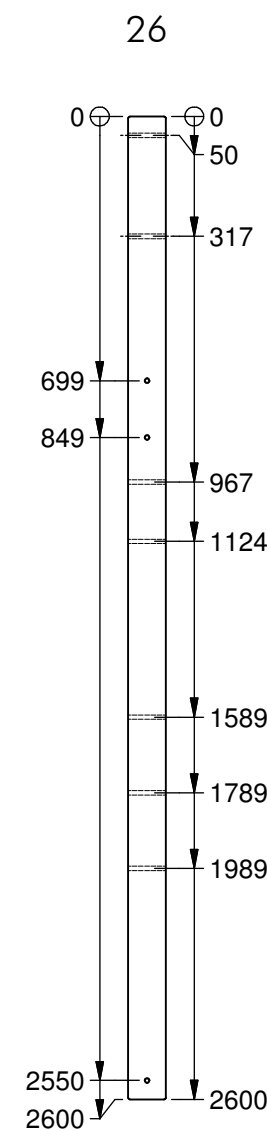
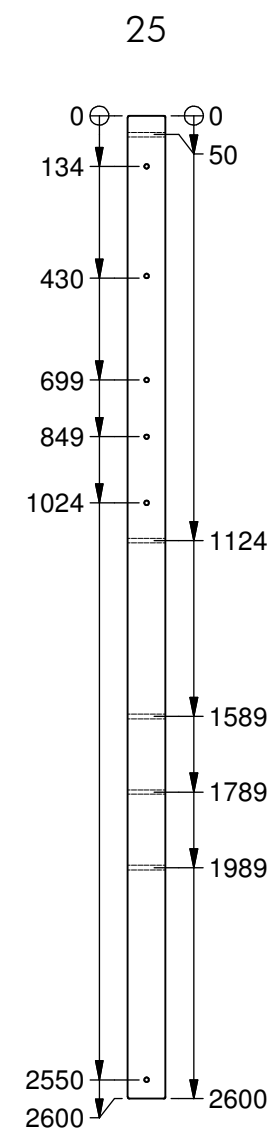
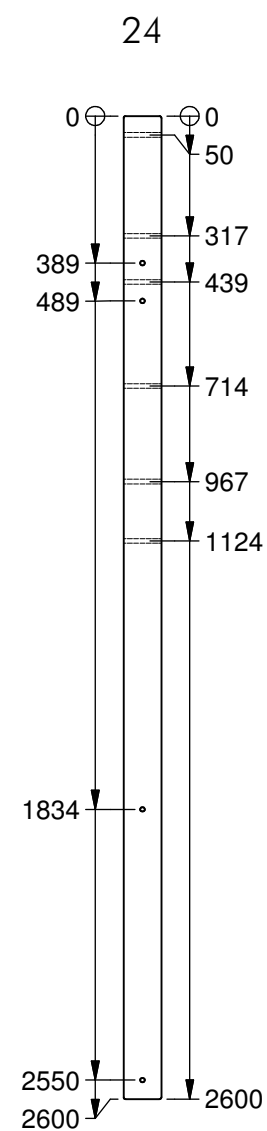
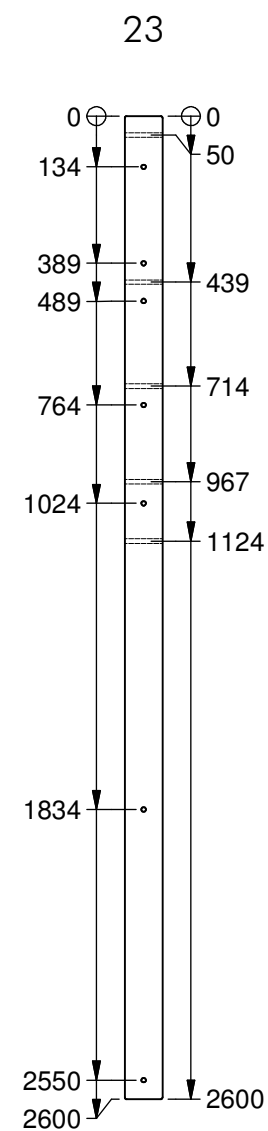
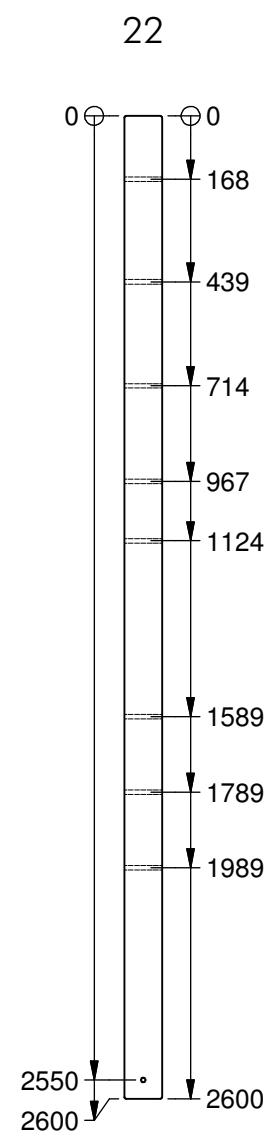
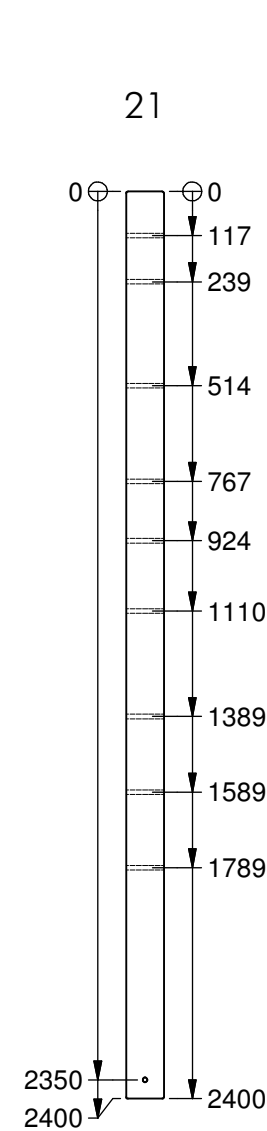
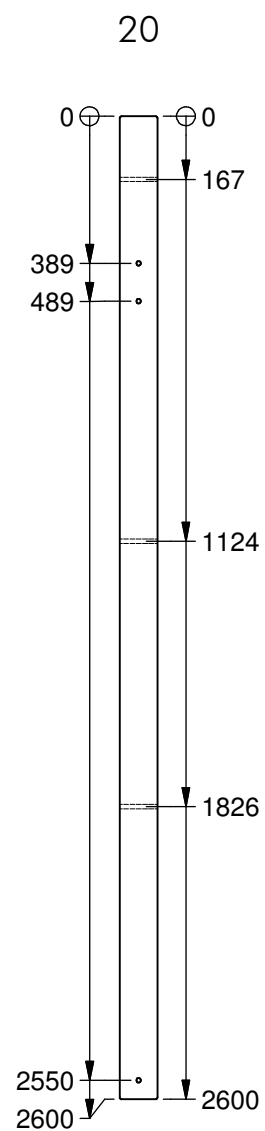
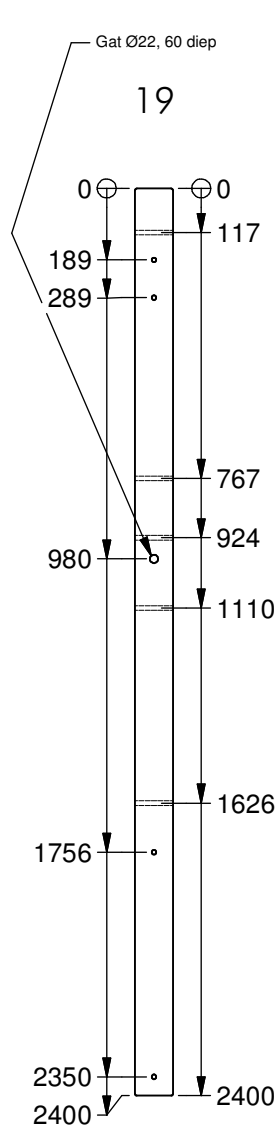

All holes Ø12 unless otherwise stated.
 All holes pierce unless otherwise stated.
 All the holes in the heart of the post, unless otherwise stated.
 Alle gaten Ø12 tenzij anders vermeld.
 Alle gaten doorboren tenzij anders vermeld.
 Alle gaten in hart van de paal tenzij anders vermeld.



Benaming Title Rebo pakket
 Opmerking Comment Schip
 Datum Date 31-8-2015

Tekening Drawing

MOD MNP 403 001

Zaag- en boorstaat Cut and drill table

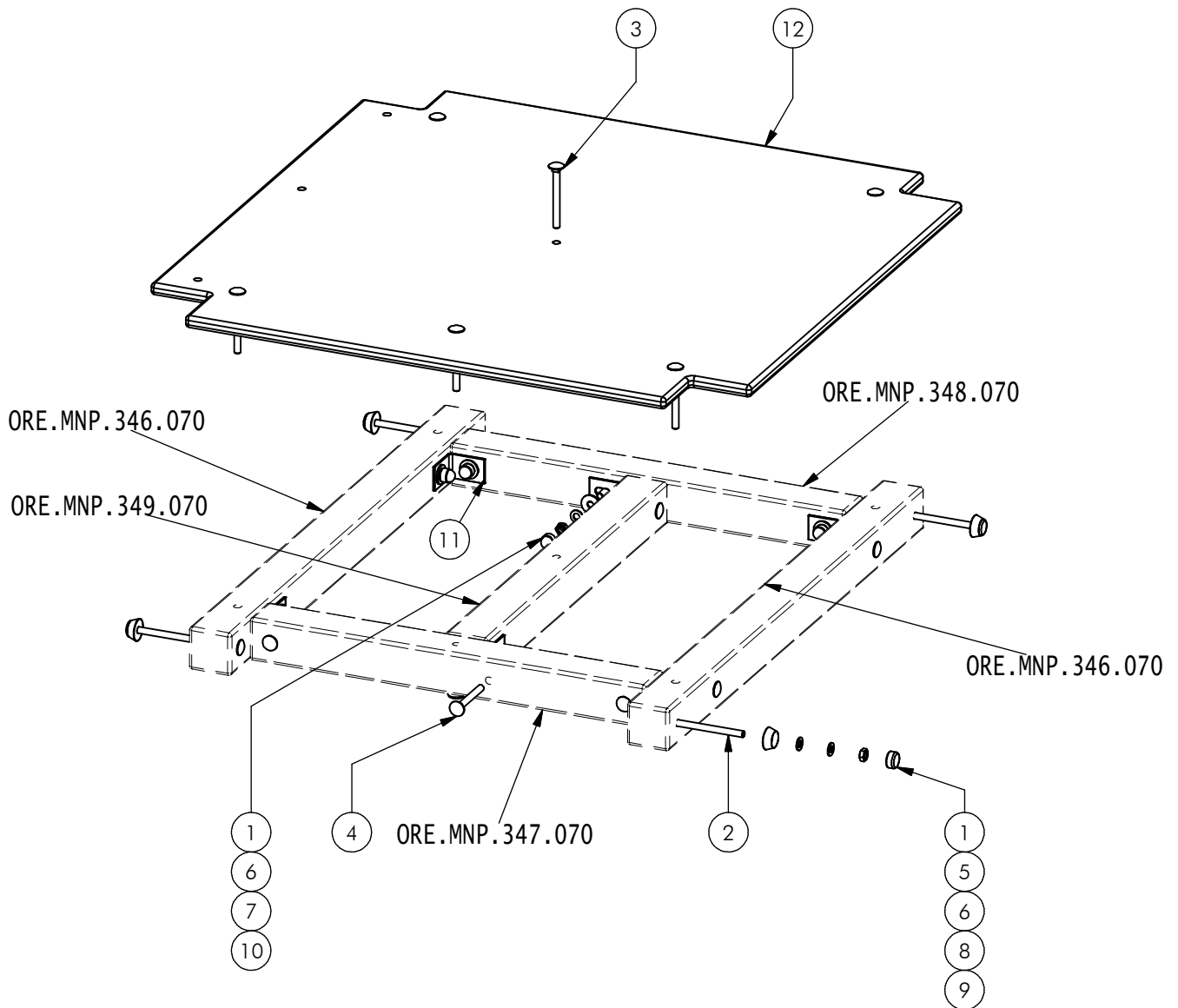

Nr	#	Type	Progr.	Volgnr	Bew.	Rev.	Benaming	Opmerking
1	22	BSV	017	010	008		Zeskantmoer	M10 - VZ 8.8
2	4	BSV	026	010	180		Slotbout	M10 x 180 - VZ 8.8
3	6	BSV	026	010	100		Slotbout	M10 x 100 - VZ 8.8
4	12	BSV	026	010	090		Slotbout	M10 x 90 - VZ 8.8
5	10	BSV	030	010	002		Sluitering	M10 - VZ 8.8
6	22	BSV	032	010	002		Veerring	M10 - VZ 8.8
7	12	BSV	035	010	030		Carrosseriering	M10 x 30 - VZ 8.8
8	10	KST	DON	011	090		interplay donut	zwart
9	10	KST	DOP	011	090		interplay dop	zwart
10	12	KST	ZKD	010	021		Afdekdop zeskantbout	M10 zwart
11	6	OME	MNP	009	320		Hoekje model 1	
12	1	OPE	MNP	402	030		Bordesplaat	Schip



Benaming
Title Bordes

Opmerking
Comment Schip

Datum
Date 31-8-2015

Tekening
Drawing

MOD MNP 403 002

Samenstelling module Assembly module

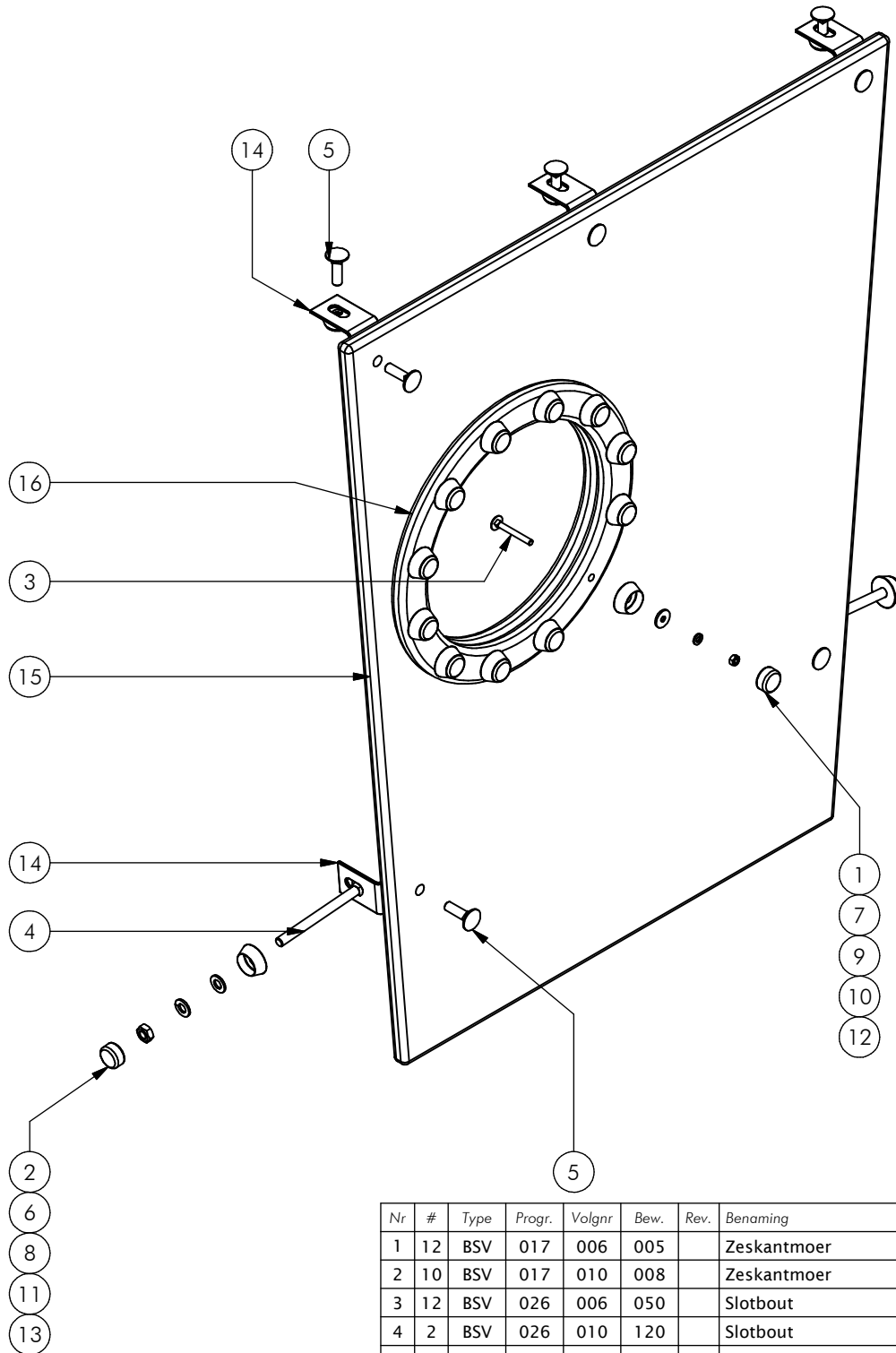

Nr	#	Type	Progr.	Volgnr	Bew.	Rev.	Benaming	Opmerking
1	12	BSV	017	006	005		Zeskantmoer	M6 - VZ 8.8
2	10	BSV	017	010	008		Zeskantmoer	M10 - VZ 8.8
3	12	BSV	026	006	050		Slotbout	M6 x 50 Verzinkt
4	2	BSV	026	010	120		Slotbout	M10 x 120 - VZ 8.8
5	8	BSV	026	010	035		Slotbout	M10 x 35 - VZ 8.8
6	10	BSV	030	010	002		Sluitring	M10 - VZ 8.8
7	12	BSV	034	006	002		Veerring	M6 - VZ 8.8
8	10	BSV	032	010	002		Veerring	M10 - VZ 8.8
9	12	BSV	035	006	020		CARROSSERIERING	M6 x 20 - VZ 8.8
10	12	KST	DON	011	020		interplay donut M10 wit	84395000012
11	10	KST	DON	011	090		interplay donut	zwart
12	12	KST	DOP	011	020		interplay dop M10 wit	84395000014
13	10	KST	DOP	011	090		interplay dop	zwart
14	5	OME	MNP	009	320		Hoekje model 1	
15	1	OPE	MNP	404	050		Wand met raam	Schip
16	1	OPE	MNP	396	030		Kozijn	Schip



Benaming Title Wandje
 Opmerking Comment Met raam
 Datum Date 4-9-2015

Tekening Drawing

MOD MNP 403 003

Samenstelling module Assembly module

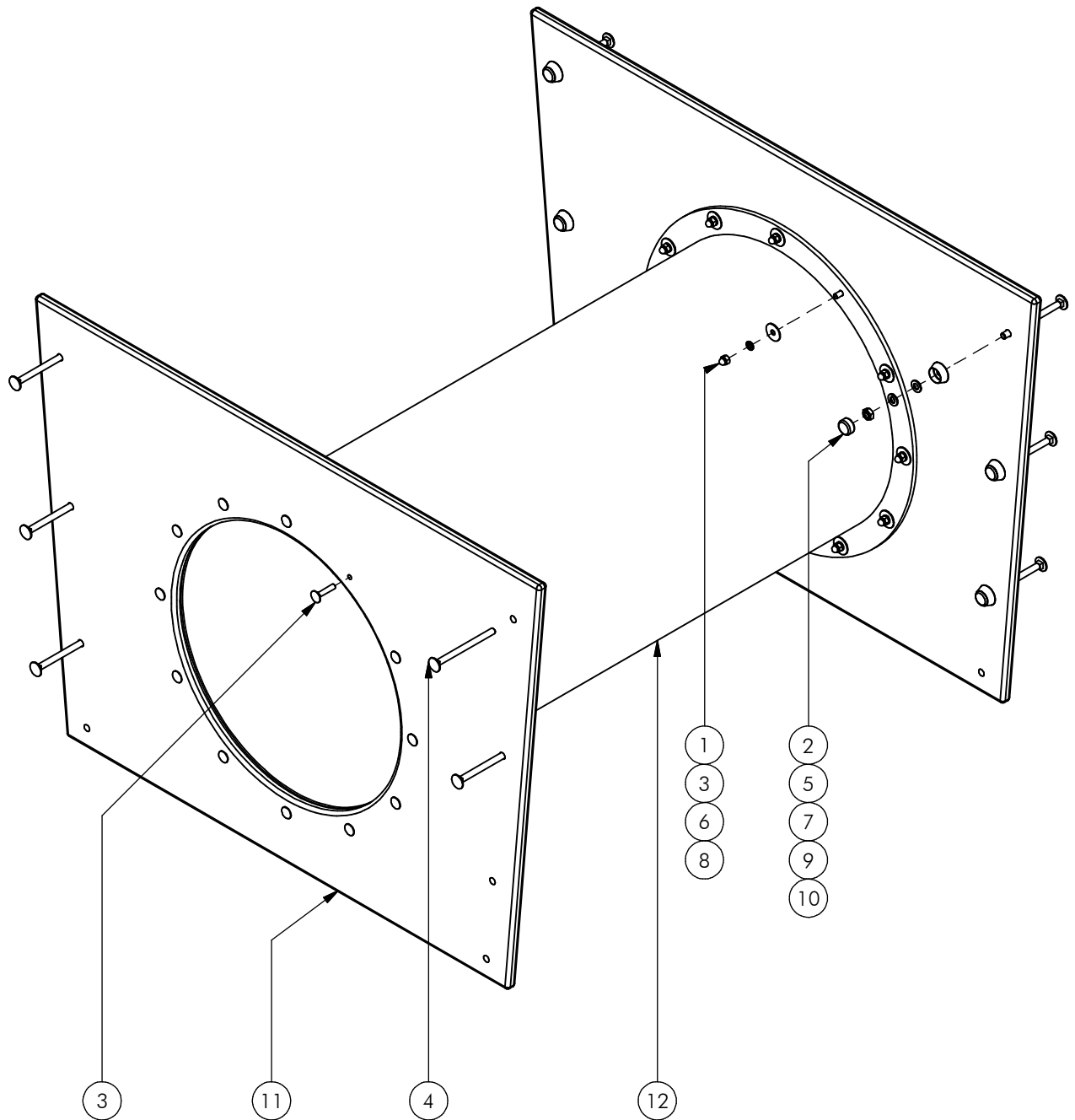

Nr	#	Type	Progr.	Volgnr	Bew.	Rev.	Benaming	Opmerking
1	24	BSV	012	008	015		Dopmoer	M8 - VZ 8.8
2	10	BSV	017	010	008		Zeskantmoer	M10 - VZ 8.8
3	24	BSV	026	008	040		Slotbout	M8 x 40 - VZ 8.8
4	10	BSV	026	010	130		Slotbout	M10 x 130 - VZ 8.8
5	10	BSV	030	010	002		Sluitring	M10 - VZ 8.8
6	24	BSV	032	008	002		Veerring	M8 - VZ 8.8
7	10	BSV	032	010	002		Veerring	M10 - VZ 8.8
8	24	BSV	035	008	030		CARROSSERIERING	M8 x 30 - VZ 8.8
9	10	KST	DON	323	090		interplay donut	zwart
10	10	KST	DOP	323	090		interplay dop	zwart
11	2	OPE	MNP	403	030		Wand	Kruipbuis
12	1	POL	MNP	010	502		kruipbuis	Mini Play



Benaming
Title | Kruipbuis

Opmerking
Comment | Schip

Datum
Date | 31-8-2015

Tekening
Drawing

MOD MNP 403 004

Samenstelling module Assembly module

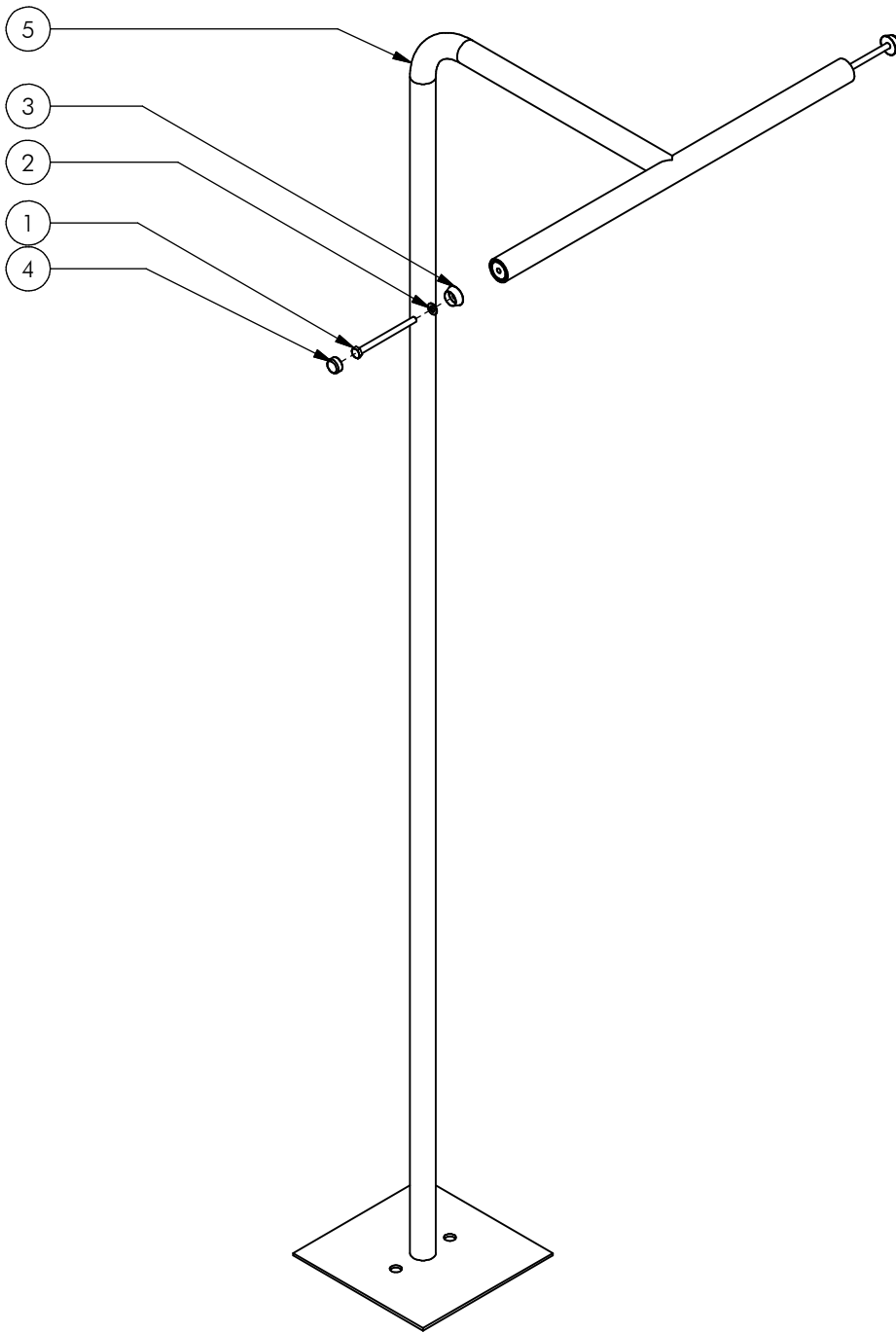

Nr	#	Type	Progr.	Volgnr	Bew.	Rev.	Benaming	Opmerking
1	2	BSV	021	010	130		Zeskantbout ISO 4014	M10 x 130 - VZ 8.8
2	2	BSV	030	010	002		Sluitring	M10 - VZ 8.8
3	2	KST	DON	011	090		interplay donut	zwart
4	2	KST	DOP	011	090		interplay dop	zwart
5	1	SME	MNP	110	502		Glijstang	Schip



Benaming
Title | Glijstang

Opmerking
Comment | Schip

Datum
Date | 31-8-2015

Tekening
Drawing

MOD MNP 403 005

Samenstelling module *Assembly module*

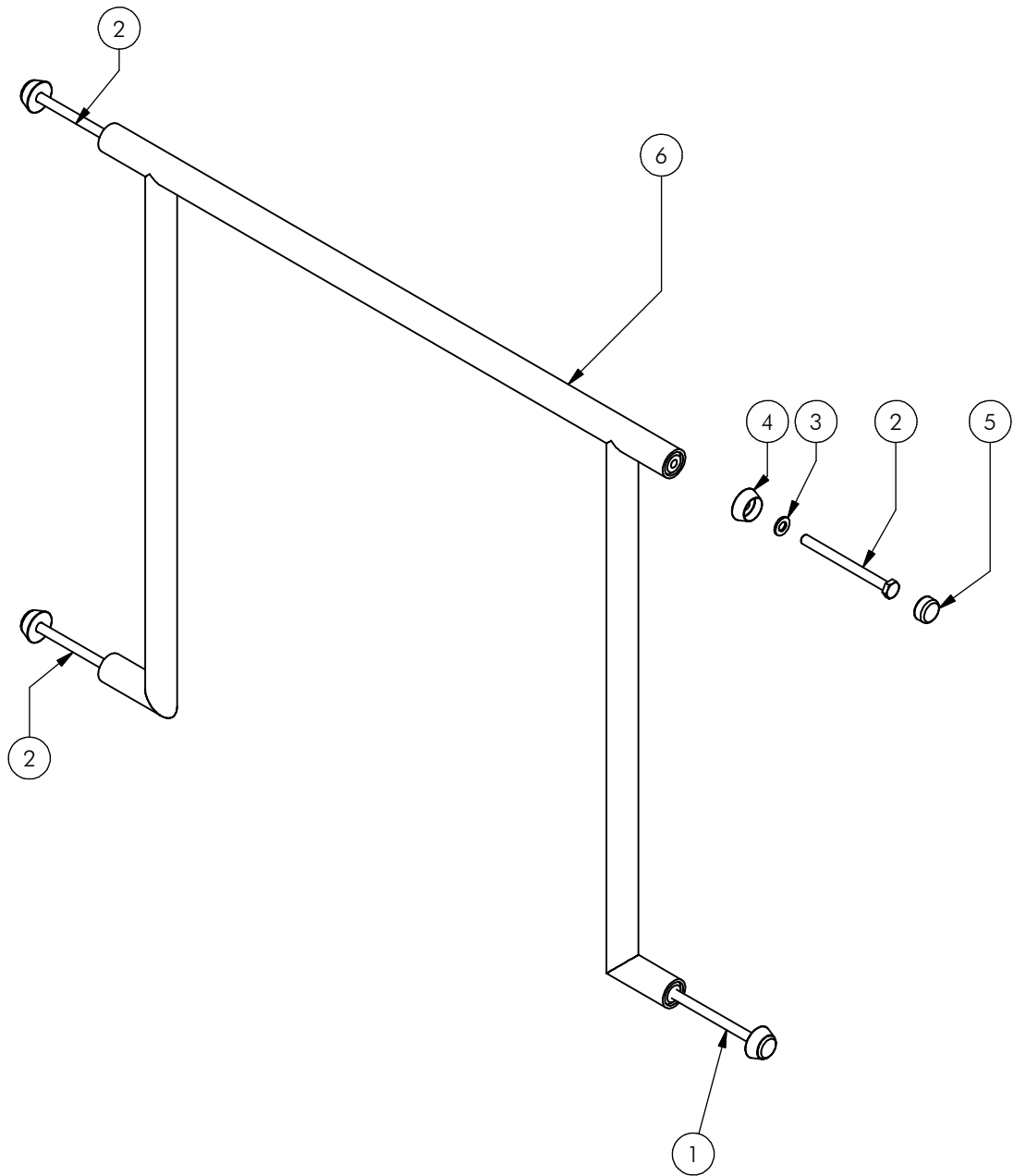

Nr	#	Type	Progr.	Volgnr	Bew.	Rev.	Benaming	Opmerking
1	1	BSV	021	010	140		Zeskantbout ISO 4014	M10 x 140 - VZ 8.8
2	3	BSV	021	010	120		Zeskantbout ISO 4014	M10 x 120 - VZ 8.8
3	4	BSV	030	010	002		Sluitring	M10 - VZ 8.8
4	4	KST	DON	011	090		interplay donut	zwart
5	4	KST	DOP	011	090		interplay dop	zwart
6	1	SME	MNP	111	502		Terugdringstang	



Benaming
Title Terugdringstang

Opmerking
Comment Schip

Datum
Date 31-8-2015

Tekening
Drawing

MOD MNP 403 006

Samenstelling module Assembly module

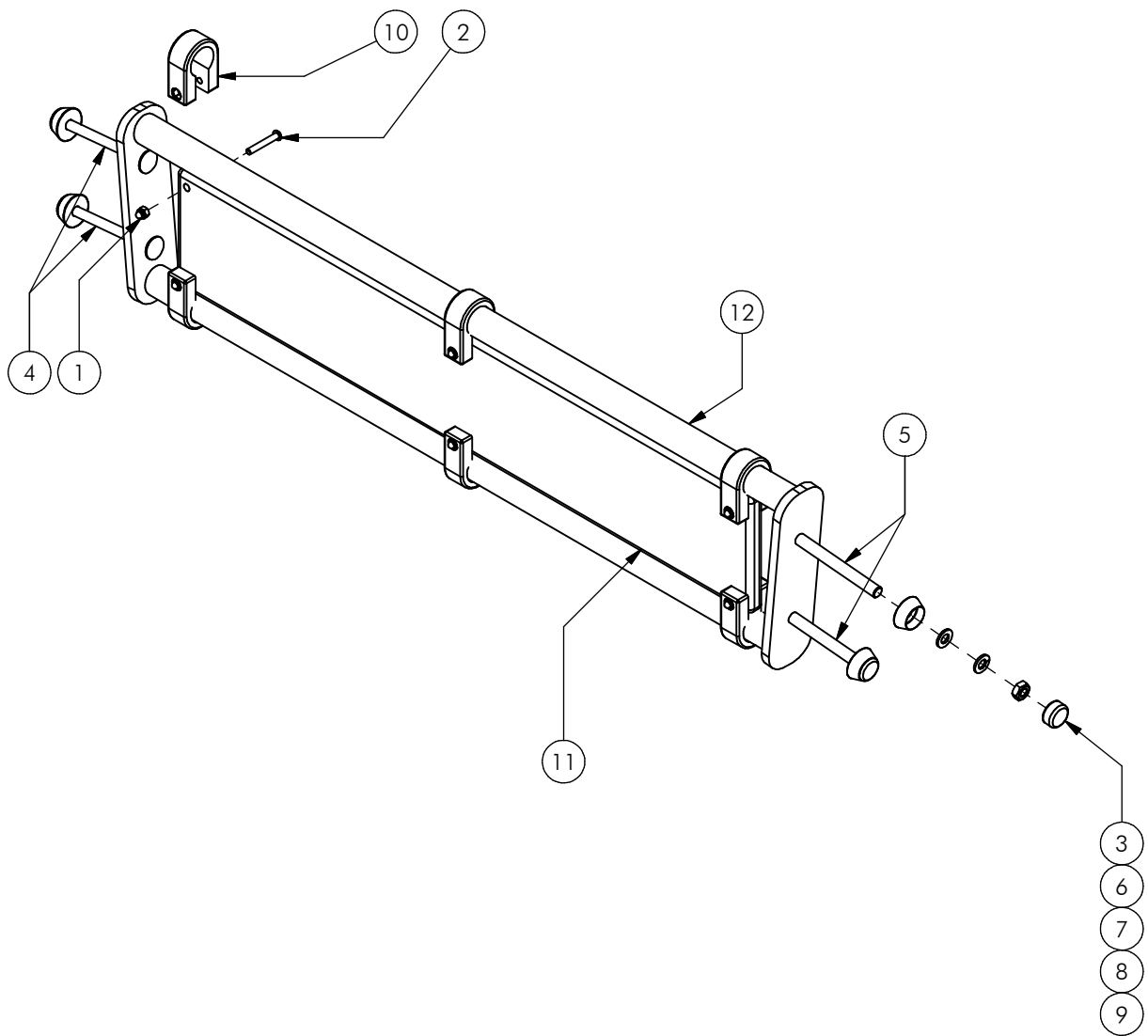

Nr	#	Type	Progr.	Volgnr	Bew.	Rev.	Benaming	Opmerking
1	6	BSR	011	006	012		Borgdopmoer	M6 - RVS A2-70
2	6	BSR	025	006	040		Veiligheids Bout	Pin-Torx - RVS A2-70
3	4	BSV	017	010	008		Zeskantmoer	M10 - VZ 8.8
4	2	BSV	026	010	120		Slotbout	M10 x 120 - VZ 8.8
5	2	BSV	026	012	120		Slotbout	M12 x 120 - VZ 8.8
6	4	BSV	030	010	002		Sluitring	M10 - VZ 8.8
7	4	BSV	032	010	002		Veerring	M10 - VZ 8.8
8	4	KST	DON	011	090		interplay donut	zwart
9	4	KST	DOP	011	090		interplay dop	zwart
10	6	KST	KLM	032	030		Klembeugel rood 32mm	80095001005
11	1	OPE	MNP	388	010		Leuning recht	Stuurzijde
12	1	SME	MNP	112	502		Leuning	Schip



Benaming Title Reling
 Opmerking Comment Schip
 Datum Date 31-8-2015

Tekening Drawing

MOD MNP 403 007

Samenstelling module Assembly module

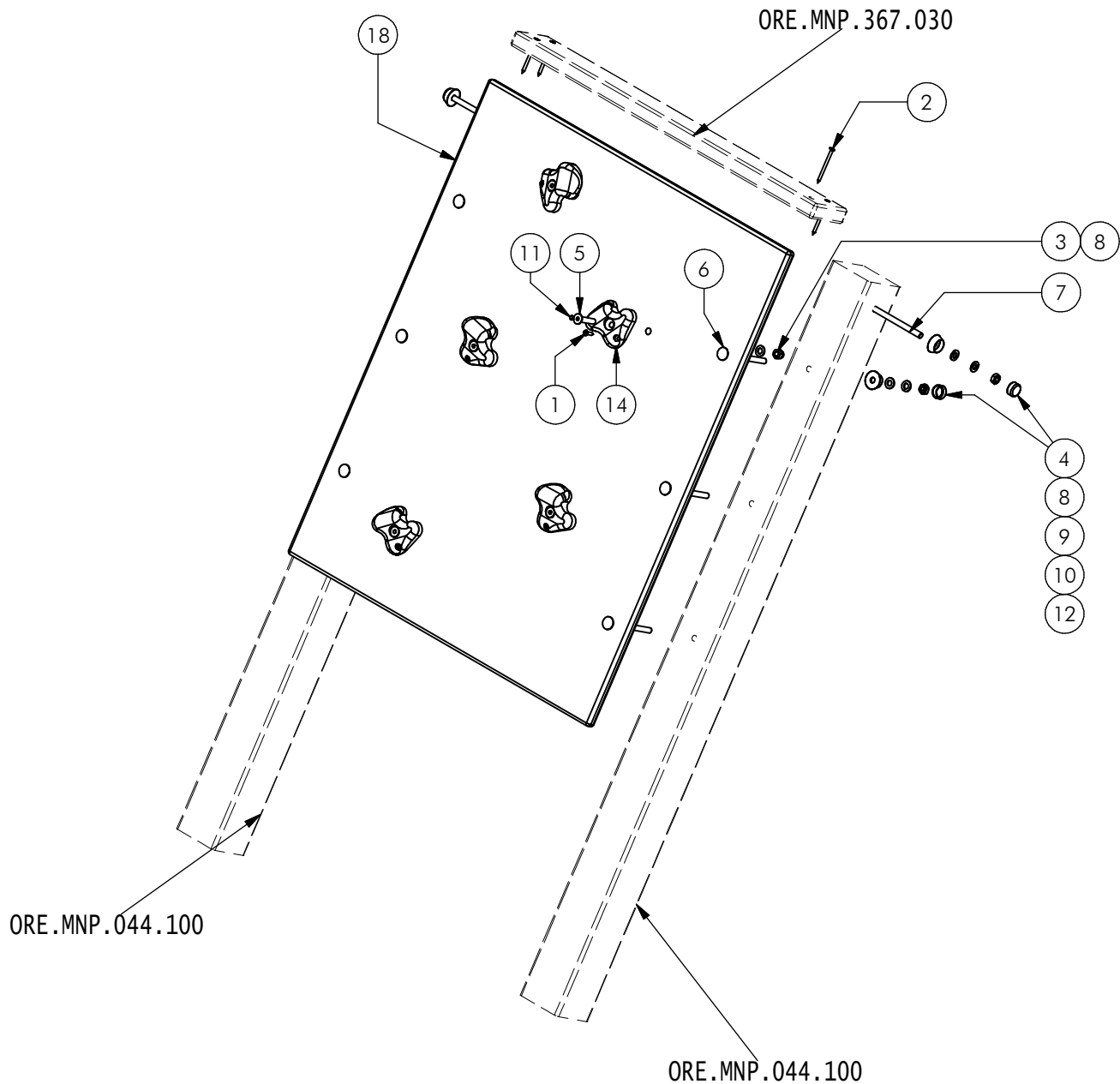

Nr	#	Type	Progr.	Volgnr	Bew.	Rev.	Benaming	Opmerking
1	5	BSV	004	005	025		Schroef verz.	5 x 25 - VZ 8.8
2	4	BSV	004	005	070		Schroef verz.	5 x 70 - VZ 8.8
3	5	BSV	011	010	020		Borgdopmoer	M10 - VZ 8.8
4	8	BSV	017	010	008		Zeskantmoer	M10 - VZ 8.8
5	5	BSV	024	010	050		Verzonken bout	M10 x 50 - VZ 8.8
6	6	BSV	026	010	130		Slotbout	M10 x 130 - VZ 8.8
7	2	BSV	026	010	220		Slotbout	M10 x 220 - VZ 8.8
8	13	BSV	030	010	002		Sluitring	M10 - VZ 8.8
9	8	BSV	032	010	002		Veerring	M10 - VZ 8.8
10	8	KST	DON	011	090		interplay donut	zwart
11	5	KST	DOP	006	030		OPVULDOPJE	6 MM ROOD
12	8	KST	DOP	011	090		interplay dop	zwart
13	1	KST	KNP	010	070		KLIMGREEP	GROEN
14	1	KST	KNP	010	050		KLIMGREEP	BLAUW
15	1	KST	KNP	010	040		KLIMGREEP	PAARS
16	1	KST	KNP	010	030		KLIMGREEP	ROOD
17	1	KST	KNP	010	010		KLIMGREEP	GEEL
18	1	OPE	MNP	405	050		Klimschot	



Benaming
Title | Klimschot

Opmerking
Comment | Schip

Datum
Date | 31-8-2015

Tekening
Drawing

MOD MNP 403 008

Samenstelling module *Assembly module*

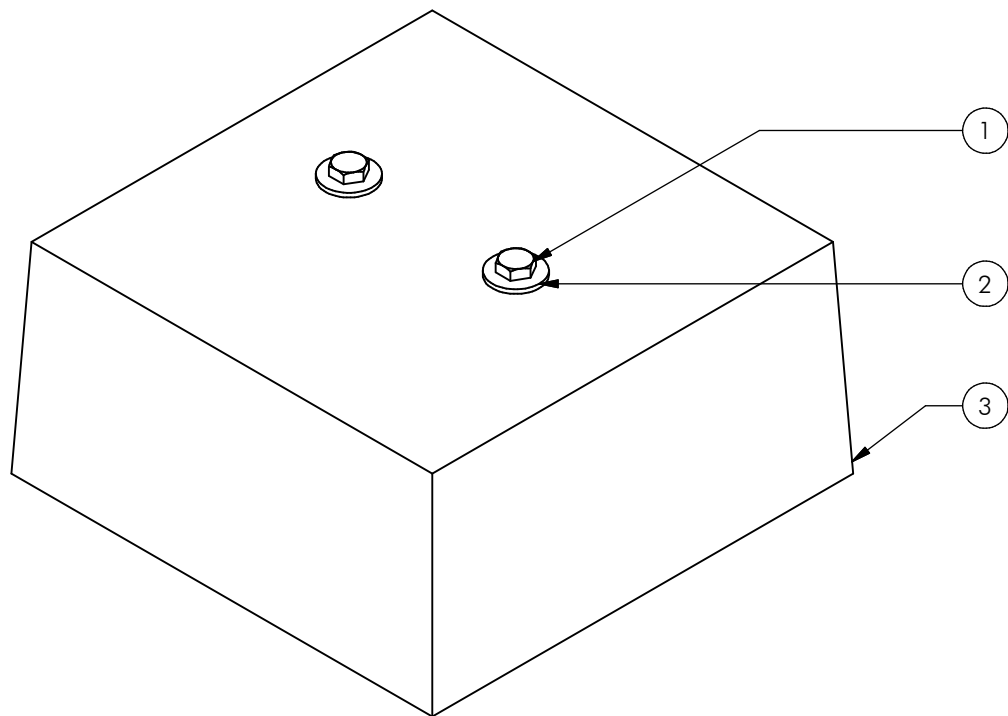

Nr	#	Type	Progr.	Volgnr	Bew.	Rev.	Benaming	Opmerking
1	2	BSV	021	012	040		Zeskantbout ISO 4014	M12 x 40 - VZ 8.8
2	2	BSV	035	012	035		Carrosseriering	M12 x 35 - VZ 8.8
3	1	OBT	POE	009	033		POER	MODEL 9



Benaming
Title Poer Model 9

Opmerking
Comment Gewicht 33,5 kg

Datum
Date 17-8-2012

Tekening
Drawing

MOD OBT 009 001

Samenstelling module *Assembly module*